

NTI BMS Gateway BACnet™

INSTALLATION AND OPERATION MANUAL

Version Date: 2024-03-04

First release



HAZARD SYMBOLS AND DEFINITIONS



Danger Sign: Indicates a hazardous situation which, if not avoided, will result in serious injury or death.



Warning Sign: Indicates a hazardous situation which, if not avoided, could result in serious injury or death.



Caution Sign plus Safety Alert Symbol: Indicates a hazardous situation which, if not avoided, could result in minor or moderate injury.

CAUTION

Caution Sign without Safety Alert Symbol: Indicates a hazardous situation which, if not avoided, could result in property damage.

NOTICE

Notice Sign: Indicates a hazardous situation which, if not avoided, could result in property damage.



This device must be installed by a licensed and trained technician, or the **Warranty is Void**. Failure to properly install this unit may result in property damage, serious injury to occupants, or possibly death.

Contents

1 INTRODUCTION 3

1.1 SYSTEM DESCRIPTION 3

1.2 GENERAL INSTALLATION REQUIREMENTS 3

1.3 USER RESPONSIBILITIES 3

1.4 INSTALLER RESPONSIBILITIES 3

1.5 DIMENSIONS 4

2 LOCATION 5

3 MOUNTING INSTRUCTIONS 6

4 FIELD WIRING 7

4.1 WIRING CONNECTIONS 7

5 INTERNAL WIRING 9

5.1 FACTORY WIRING 9

5.2 FUSING 9

6 SETUP & COMMISSIONING 10

6.1 INITIAL PROCEDURES 10

6.2 ENABLE EXTERNAL CONTROL OF BOILER(S) 10

6.2.1 Control Mode (42.0.0) = Disabled 10

6.2.2 Control Mode (42.0.0) = 0-10V (Power/Temp) 10

6.2.3 Control Mode (42.0.0) = External controller power/temp 11

6.3 SELECT BMS PROTOCOL 11

6.3.1 Connect PC to ProtoNode 11

6.3.2 Configure PC IP address 11

6.3.3 Navigate to the login page 11

6.3.4 Select security mode 11

6.3.5 Select the protocol 11

6.3.6 Select the MS/TP serial Baud rate 13

7 TROUBLESHOOTING 14

8 DATAPOINTS 15

8.1 ERRORS 15

8.2 BUILDING MANAGEMENT SYSTEM (BMS) SERVICE 15

8.3 CENTRAL HEATING (CH) 15

8.4 DOMESTIC HOT WATER (DHW) 15

8.5 CASCADE MANAGER 15

8.6 COMMERCIAL BOILER MASTER 16

8.7 HEATING ZONE 1 16

8.8 HEATING ZONE 2 16

8.9 HEATING ZONE 3 17

8.10 HEATING ZONE 4 17

8.11 HEATING ZONE 5 18

8.12 HEATING ZONE 6 18

8.13 SOLAR MANAGER 18

8.14 ERROR OWNER MULTISTATE VALUES 20

8.15 STATUS CODE 21

1 INTRODUCTION

1.1 System Description

The NTI BMS Gateway BACnet™ provides an interface between NTI TFTN series boilers, up to 8 boilers maximum and a building management system that uses BACnet™ protocol for communication. ***IMPORTANT NOTE:*** To connect multiple boilers using a single BMS Gateway, the boilers ***MUST*** be configured in a cascade arrangement. The gateway supports BACnet MS/TP with RS485 electrical interface, and BACnet/IP on Ethernet CAT5 cabling. The gateway comprises two main components: an eBUS2-Modbus gateway to translate Ariston proprietary eBUS2 protocol to open Modbus protocol; then a ProtoNode FPC-N54 gateway to translate Modbus to BACnet™. Refer to the ProtoNode FPC-N54 Start-up Guide (NTI part # 420011338100) for more details. ***IMPORTANT NOTE:*** For multiple boilers that are ***NOT*** configured in a cascade arrangement, ***ONE*** BMS Gateway is required ***PER BOILER***.

1.2 General Installation Requirements

The installation of your NTI BMS Gateway must conform to the requirements of this manual, your local authority, and the Canadian Electrical Code CSA 22.1 and/or NFPA 70 National Electrical Code®. ***IMPORTANT NOTE:*** The installer ***MUST*** have access to a personal computer (PC) running Windows 10 or later, a web browser (Google Chrome™ is recommended), and a CAT 5 or CAT 6 Ethernet patch cord to connect to the service port of the ProtoNode.



Read and understand this entire document prior to proceeding with the installation of the NTI BMS Gateway. Failure to follow the instructions outlined in this document will result in property damage, serious injury or death.

1.3 User Responsibilities

The NTI BMS Gateway must be installed and serviced by a qualified installer or service technician. The product is designed for use with boiler equipment and may only be serviced by authorized competent personnel.

1.4 Installer Responsibilities

As the installing technician it is your responsibility to ensure the installation is performed in accordance with this instruction manual as well as any applicable local or National installation codes. It is also your responsibility to inform the User/Owner of the "[User Responsibilities](#)". Failure to follow this warning could result in fire, serious injury, or death.

1.5 Dimensions

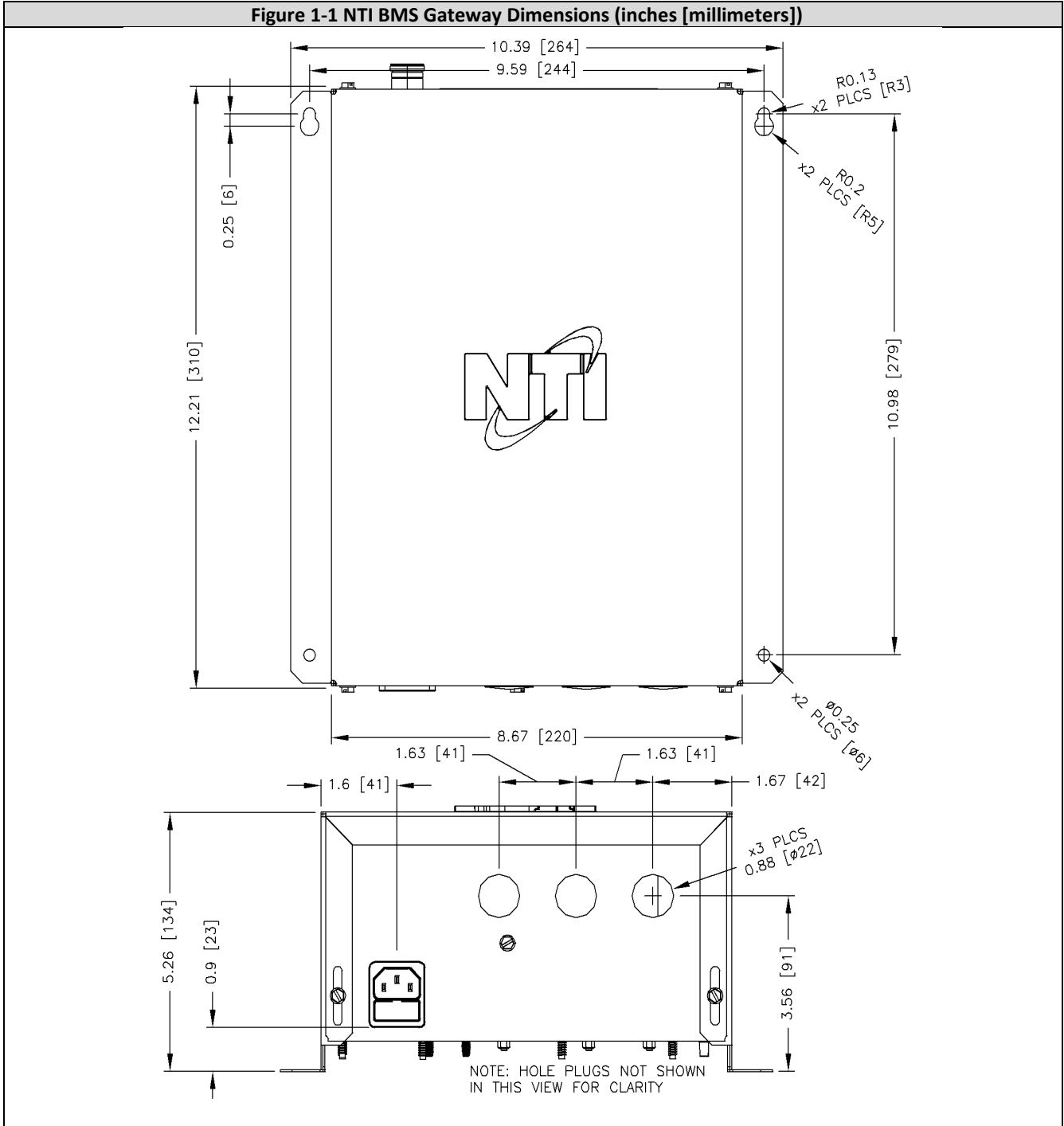

2 LOCATION

In all cases, the NTI BMS Gateway must be installed indoors in a dry location where the ambient temperature must be maintained between 0°C [32°F] and 60°C [140°F]. All components must be protected from dripping, spraying water, or rain during operation and servicing. Consider the proximity of the target boiler(s) and electrical supply when determining the best location.



Water damaged components must be replaced immediately with new factory-approved components as failure to do so may result in fire, serious injury, or death.

Minimum Installation Clearances

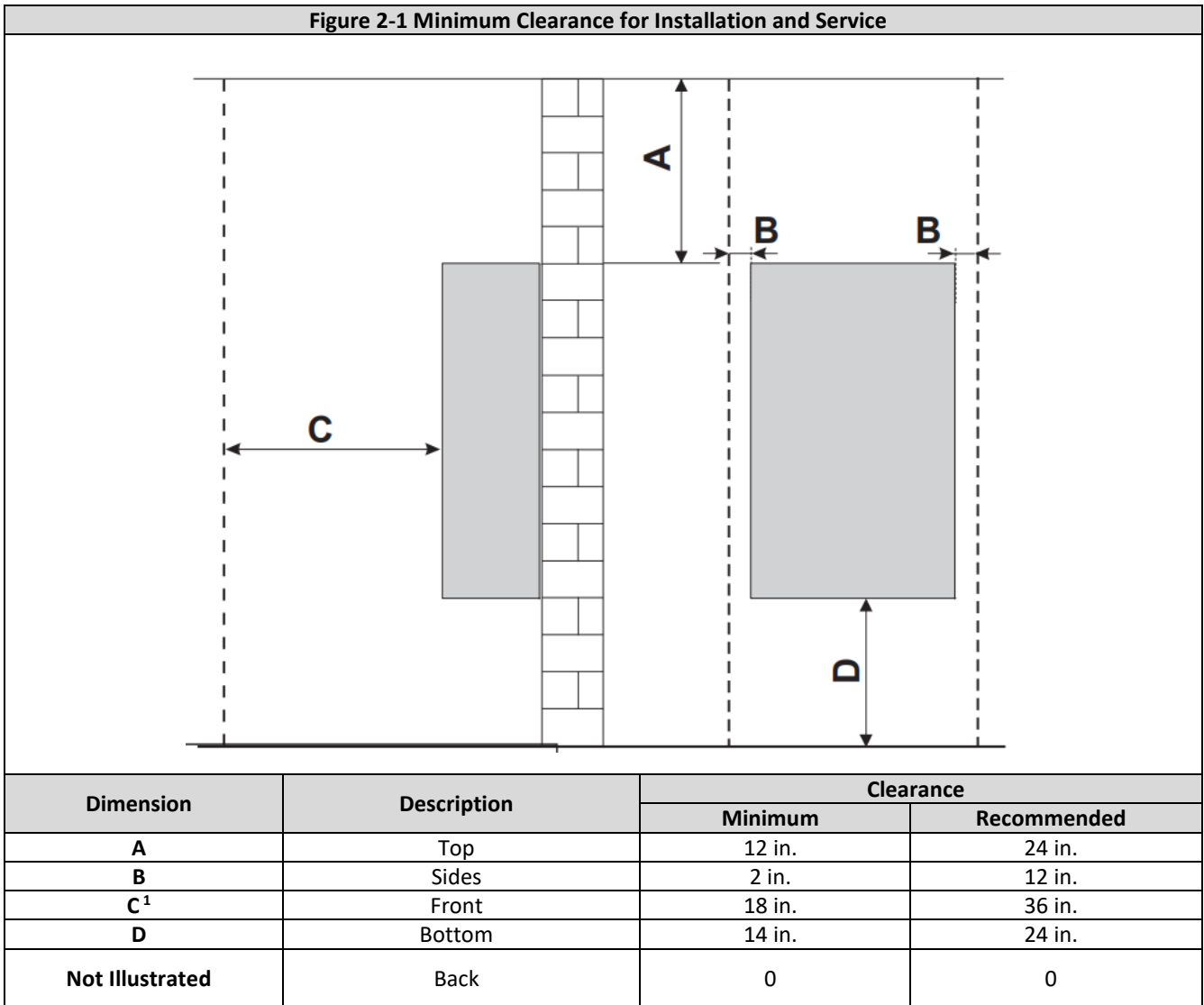

3 MOUNTING INSTRUCTIONS

The NTI BMS Gateway is provided with integral mounting brackets. Refer to Figure 3-1 for instructions and illustrations on wall mounting. Mounting hardware must be field supplied.

Figure 3-1 Mounting Instructions

1. Mounting is permitted in any orientation, vertical on a wall (as illustrated below) is recommended.
2. Use #8 or #10 pan head screws of appropriate length.
3. Place gateway in selected location on clean, dry surface.
4. Mark top hole locations. Be sure to mark the upper narrow opening of the keyhole slot.
5. If masonry or wallboard surface, pre-drill pilot holes for anchors, and insert anchors.
6. Secure gateway to the surface with screws. Install top two screws first.
7. Mark bottom hole locations. Install anchors if needed, and secure gateway to surface.

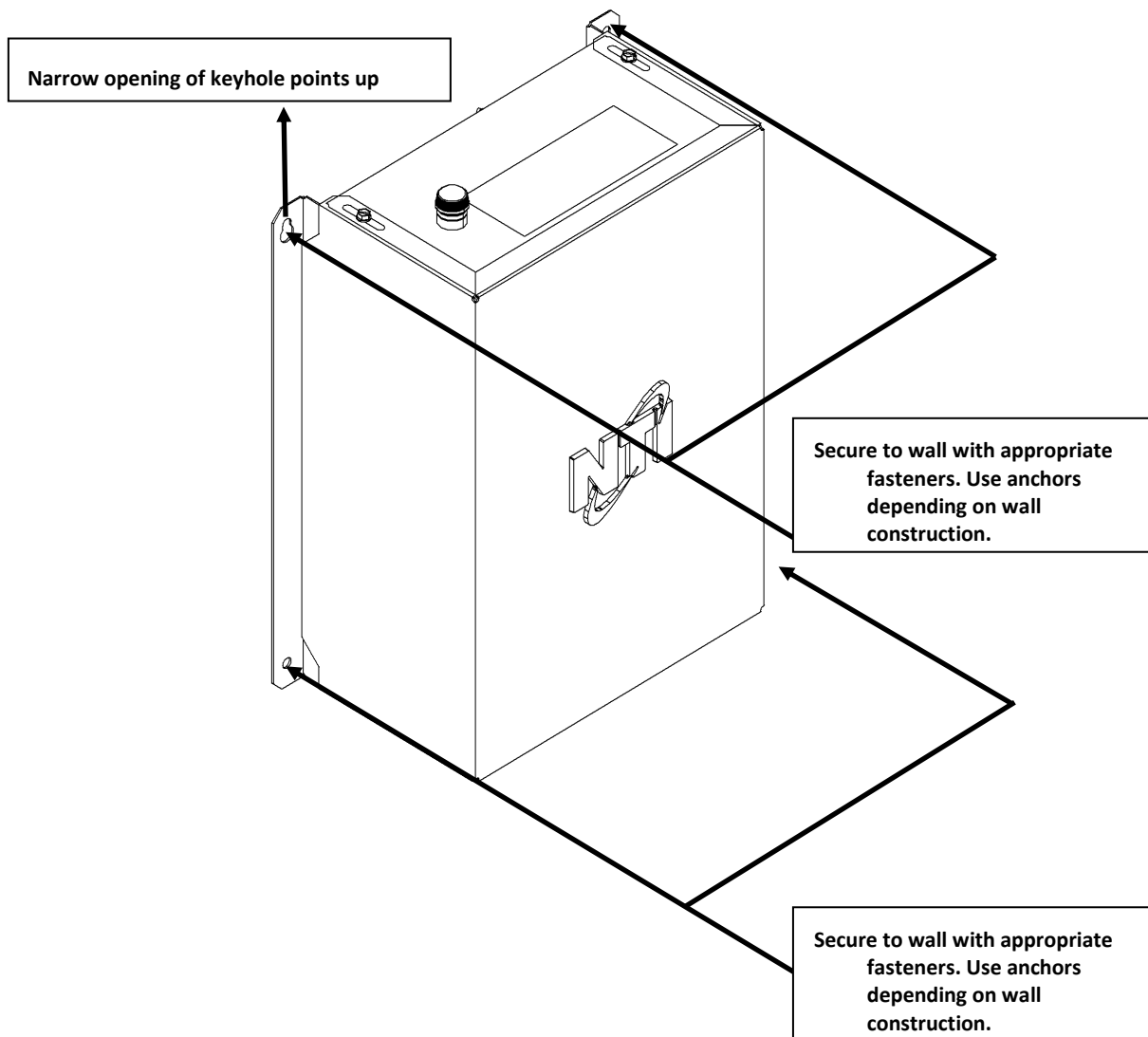

4 FIELD WIRING

All wiring must be in accordance with the Canadian Electrical code CSA C22.1 and/or the National Electrical Code ANSI/NFPA 70, local codes, and this manual. NOTICE: the gateway must be electrically grounded. The electrical rating of the NTI BMS Gateway is 120Va.c./1 Phase/60 Hz/12W.



Power Supply – the BMS gateway must be powered using a single phase 120Va.c. power supply that is fused (or protected via a circuit breaker) to allow a maximum of 15 Amps. Failure to follow these instructions may result in component failure, serious injury or death. The BMS Gateway is factory supplied with a power cord for connection to the power source. **IMPORTANT:** The installer **MUST** provide a local convenience outlet.



Avoid Shocks – To Avoid Electrical Shock, turn off electrical power to the gateway prior to opening the enclosure. Ensure the power remains off while any wiring connections are being made. Failure to follow these instructions may result in component failure, serious injury or death.

4.1 Wiring Connections

All field wiring connections to the gateway are made by removing the enclosure cover to access the internal connectors; see Figure 4-1. Field wiring enters the enclosure through holes located on the bottom (when the gateway is mounted as recommended) of the enclosure. Field wiring connections are to be installed in accordance with instructions provided in Figures 4-1 and 4-2. The NTI BMS Gateway is factory wired so that only the external wiring connections to a) the target boiler(s); and b) the BMS, as illustrated in Figure 4-2; are necessary.

NOTE: protect the wires from strain and chafing by using suitable strain-relief when passing the wiring through the gateway enclosure.

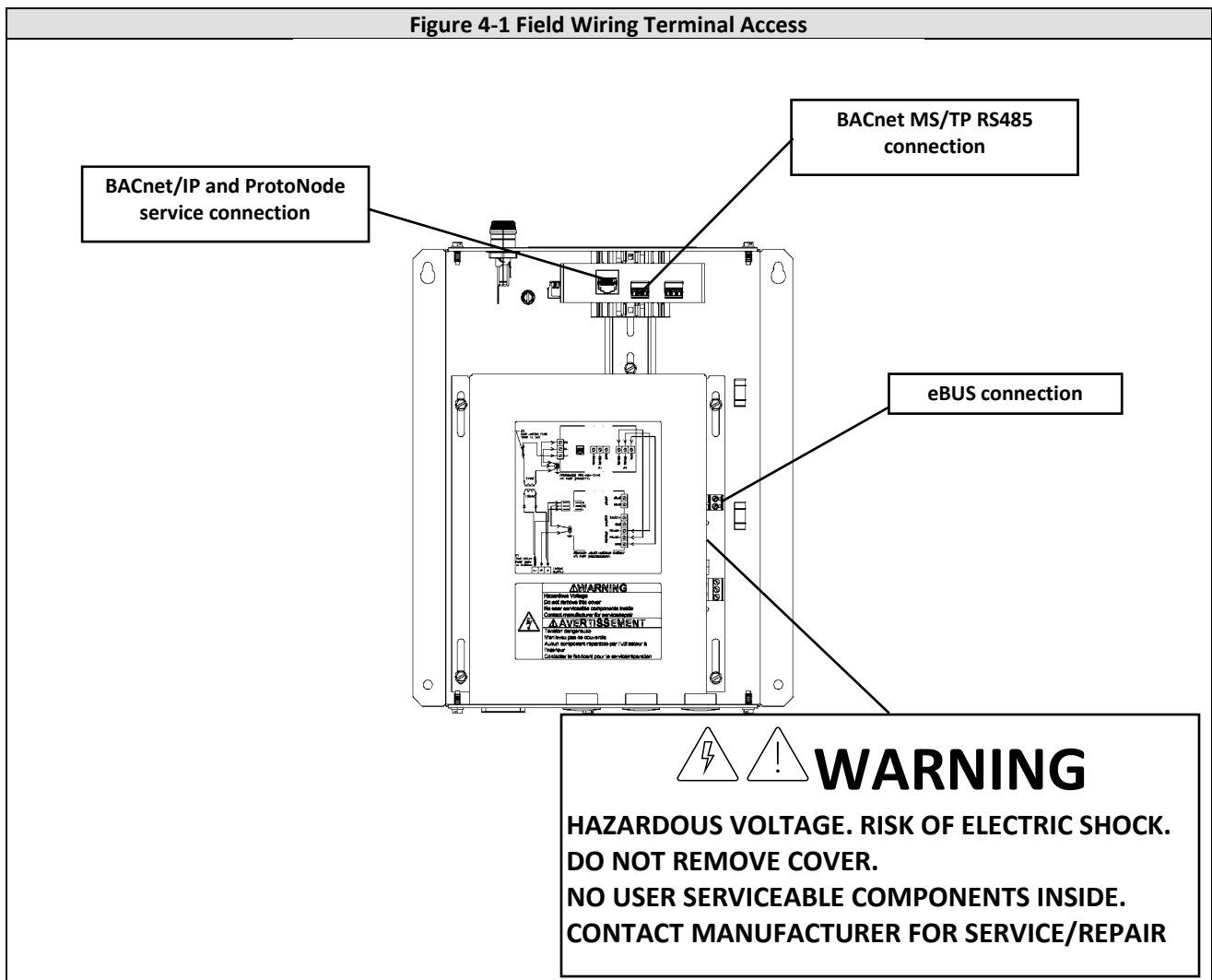



Wire Protection – When passing wiring through the gateway enclosure, the installer must use wire strain relief suitable for securing the wiring and preventing chafing. Failure to follow instructions may result in component failure, serious injury or death.



Labeling – Label all wires prior to disconnecting them when servicing controls. Wiring errors can cause improper and dangerous operation. Failure to follow instructions may result in property damage or personal injury.

Figure 4-2 Field Wiring

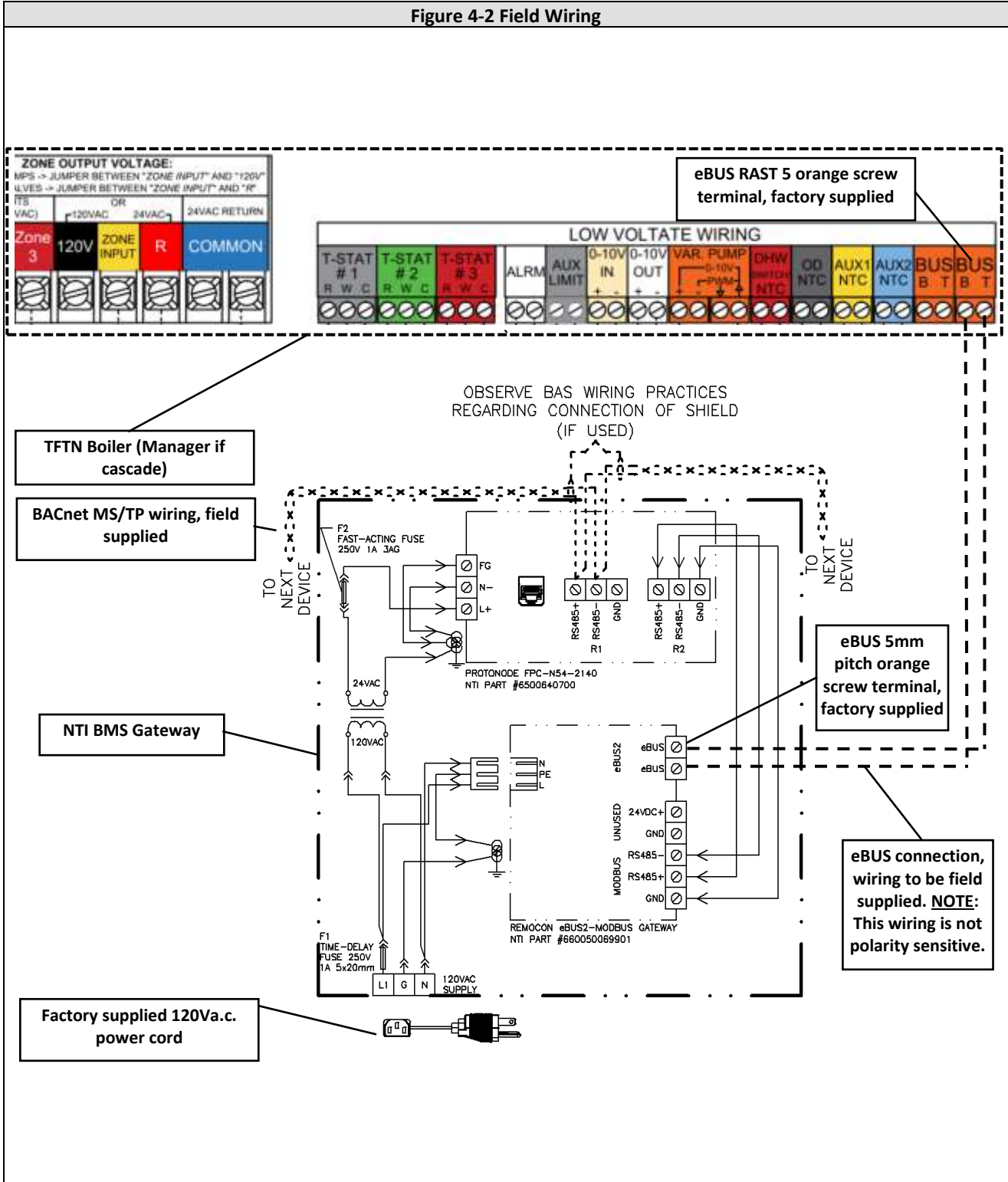

5 INTERNAL WIRING

5.1 Factory wiring

As noted above in section 4.1 above, the NTI BMS Gateway requires only the external wiring connections to: a) 120Va.c. power; b) the target boiler(s); and c) the BMS.

5.2 Fusing

External fusing: The NTI BMS Gateway incorporates 2 user replaceable fuses: 1) 250V 1 Amp fast-acting 3AG glass cartridge fuse NTI part #TBD; 2) 250V 1 Amp time-delay 5mmx20mm glass cartridge fuse NTI part #TBD.



WARNING Disconnect all power sources before replacing any fuse. Failure to do so could result in serious injury or death.

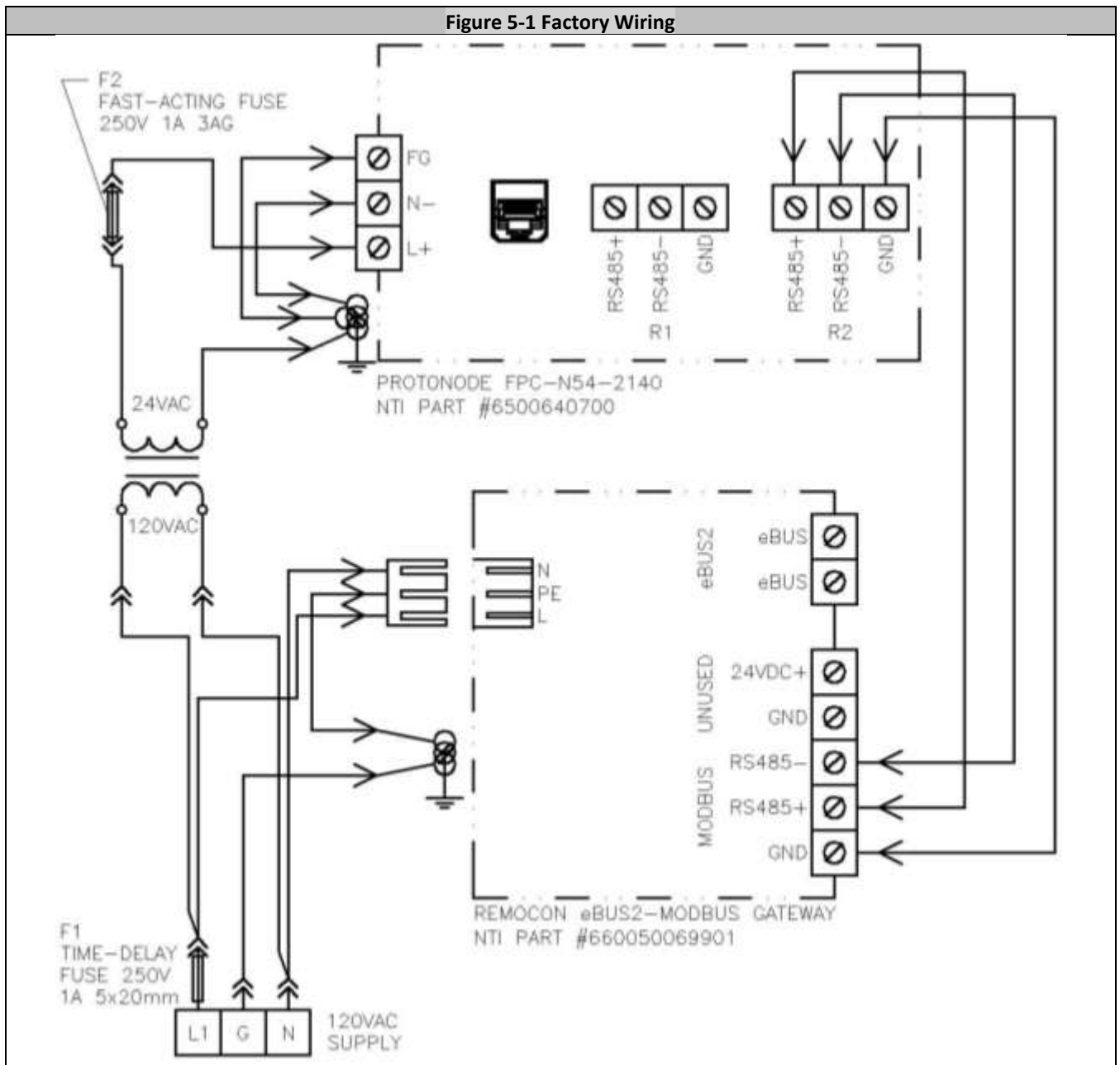

6 SETUP & COMMISSIONING

6.1 Initial procedures

Immediately following power-up of the gateway, the system will go through a process of “Device Discovery”, where the devices connected to the boiler are discovered. This is followed by an “Initializing” process.

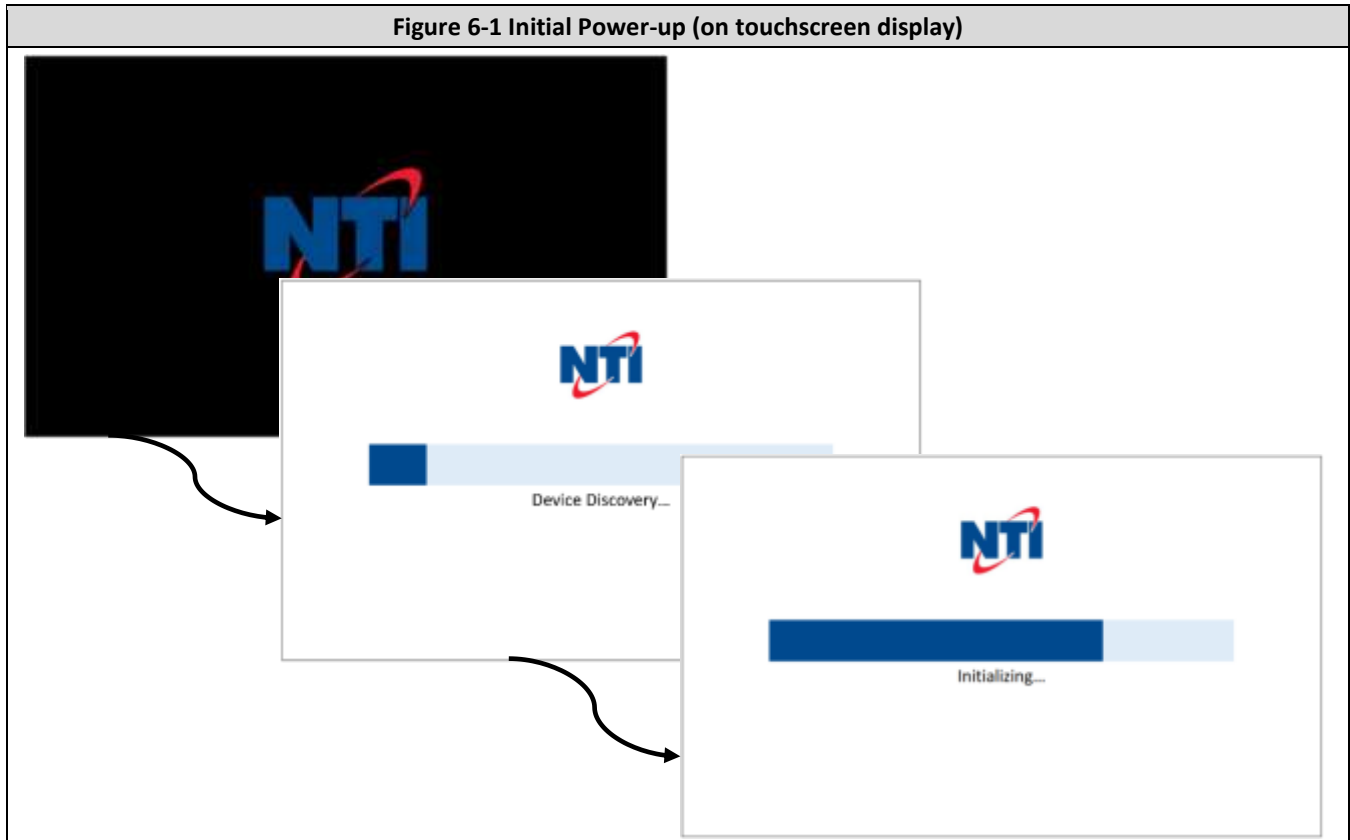

6.2 Enable external control of boiler(s)

To allow control of the boiler (or cascade) by the BMS, boiler parameter **42.0.0** must be set correctly. For a cascade, the setting must be made in the Manager boiler. From the Home screen, select Setup→Tech Menu→BMS Control→Control Mode. Then choose External controller temp for remote temperature setpoint, or External controller power for remote direct burner modulation. For more details, refer to the TFTN Installation and Operation Manual (IOM). **NOTE:** If BMS control of the boiler(s) is Disabled, the gateway will still read and transmit data points from the boiler(s), but control from the BMS will be ignored. **NOTE:** BMS setpoint and individual zone fixed outlet temperature setpoints can be written even if BMS Control Mode is Disabled. **NOTE:** No software configuration of the eBUS2-MODBUS gateway is required. The selection of the boiler’s Control Mode (42.0.0) setting impacts the level of control the BMS system has over the boiler as follows:

6.2.1 Control Mode (42.0.0) = Disabled

The gateway reads and transmits data points from the boiler, including zone fixed outlet temperature setpoints and CH enable/disable, while the boiler maintains control of the burner power and overall target outlet temperature.

NOTE: with Control Mode disabled, the boiler retains functionality of its internal 3-zone controller.

6.2.2 Control Mode (42.0.0) = 0-10V (Power/Temp)

The gateway reads and transmits data points from the boiler, including CH enable/disable, while the control of the burner power or overall target outlet temperature is dictated by the magnitude of the external 0-10V signal applied to the boiler terminals 0-10V IN.

NOTE: with Control Mode = 0-10V (Power/Temp) the boiler’s internal 3-zone controller does NOT function.

6.2.3 Control Mode (42.0.0) = External controller power/temp

The gateway reads and transmits data points from the boiler, including CH enable/disable and direct control of the burner power or target outlet temperature.

NOTE: with Control Mode = External controller power/temp the boiler’s internal 3-zone controller does NOT function.

6.3 Select BMS protocol

The installer must select the appropriate BACnet™ protocol type using the built in GUI interface of the ProtoNode. MS/TP and BACnet/IP are supported. The ProtoNode is factory set to use BACnet/IP. Refer to the ProtoNode FPC-N54 Start-up Guide for more details. The procedure consists of the following steps:

6.3.1 Connect PC to ProtoNode

Remove the NTI BMS Gateway cover and connect the PC to the ProtoNode using a CAT5 Ethernet patch cord.

6.3.2 Configure PC IP address

The default IP address of the ProtoNode is **192.168.1.24** with netmask **255.255.255.0**. Use Windows Control Panel to set the network settings of the PC with a manually entered static IP address on the same logical network as the ProtoNode. For example, use address 192.168.1.11 with netmask 255.255.255.0. Any valid address of the 192.168.1.0/24 subnet, other than 192.168.1.24, is suitable.

6.3.3 Navigate to the login page

Open a browser window and type the ProtoNode IP address **192.168.1.24** in the browser address box. Press Enter and the login page should appear. The default user name is admin, and the password is marked on a label attached to the ProtoNode case.

6.3.4 Select security mode

This is installation specific. If BACnet MS/TP protocol is selected, non-secure HTTP is adequate as a security selection for interacting with the ProtoNode. If BACnet/IP is selected, the local IT or network administrator may need to be consulted. Consult the ProtoNode FPC-N54 Start-up Guide for details.

6.3.5 Select the protocol

After successful login, the main Configuration Parameters page is displayed. Generally there is no need to modify any of the parameters other than the protocol. To select the protocol, enter 1 for BACnet/IP or 2 for BACnet MS/TP in the Protocol Selector box:

Configuration Parameters

Parameter Name	Parameter Description	Value
protocol_select	Protocol Selector Set to 1 for BACnet IP/Modbus TCP Set to 2 for BACnet MSTP	2

Protocol selection
1 = BACnet/IP
2 = BACnet MS/TP

After typing the desired choice, click the Submit button to activate the new configuration. A prompt will appear near the top of the page:

Configuration update complete. Please restart the system to load the new Configuration.

Click the System Restart button near the bottom of the page:



Confirm the restart by clicking OK:

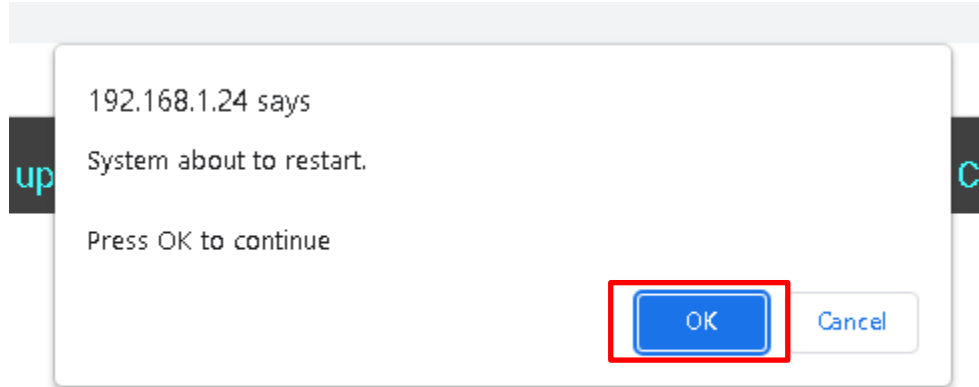

Changing the protocol will invalidate the profile, which is indicated near the bottom of the Configuration Parameters page:

Active profiles

Nr	Node ID	Current profile	Parameters
1	1	invalid profile	

Add Remove



Therefore, it is necessary to clear the profile and restart. Click the button near the page bottom to clear profiles and restart:



The page will automatically refresh with no profile available. To rediscover the eBUS2-MODBUS gateway and create a profile, click the Discovery Mode button and confirm the discovery:



Click the OK button to confirm:

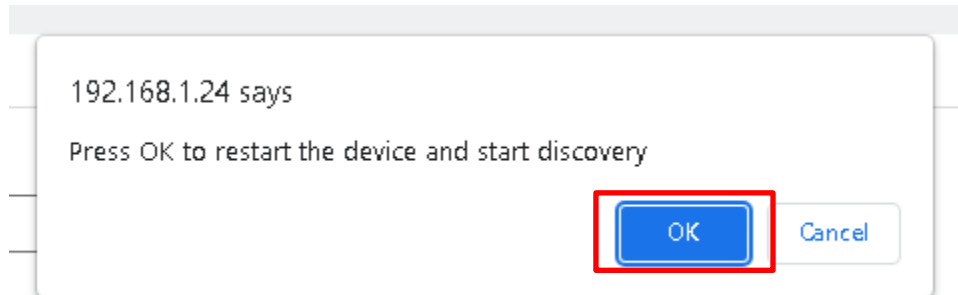

During Discovery a progress box appears:

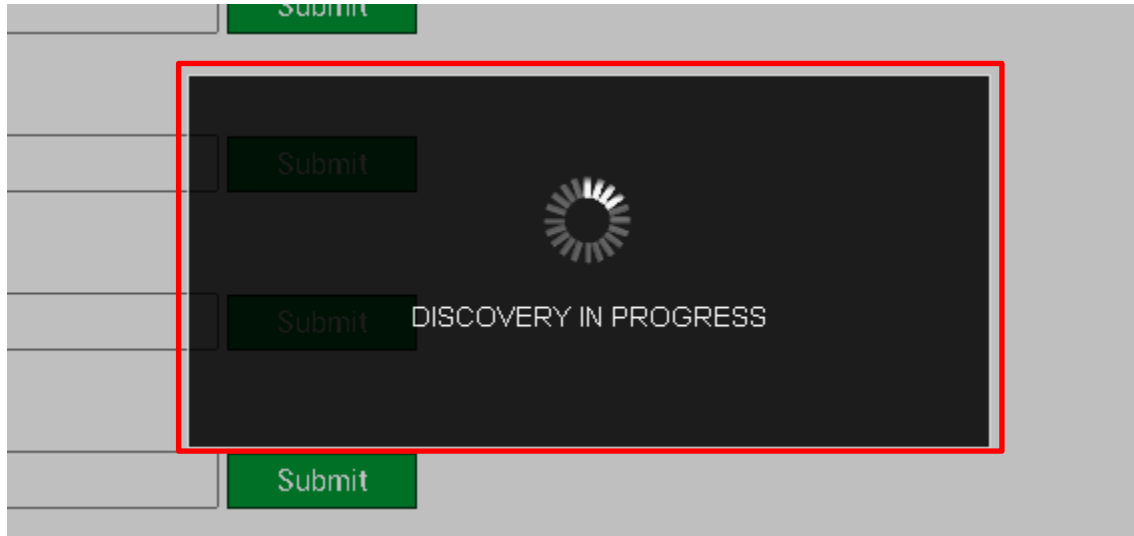

The Discovery progress % is shown near the top of the page:

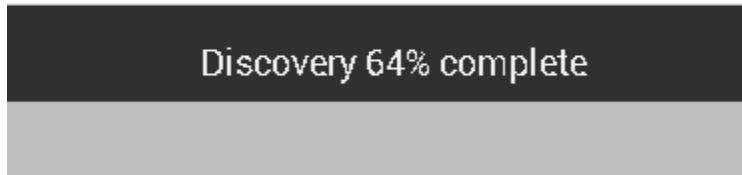

6.3.6 Select the MS/TP serial Baud rate

Only applies if the selected protocol is MS/TP. Type one of the valid rates (9600/19200/38400/76800) into the box and click Submit, then follow the onscreen instructions:

bac_baud_rate

BACnet MSTP Baud Rate
This sets the BACnet MSTP baud rate.
(9600/19200/38400/76800)

BACnet MSTP Max Master

38400

Submit

7 TROUBLESHOOTING

Refer to the ProtoNode FPC-N54 Start-up Guide for troubleshooting assistance. There are no user configurable settings for the eBUS2-MODBUS gateway. Operation of both the ProtoNode and eBUS2-MODBUS gateway is confirmed by observing the activity of LEDs on the respective devices:

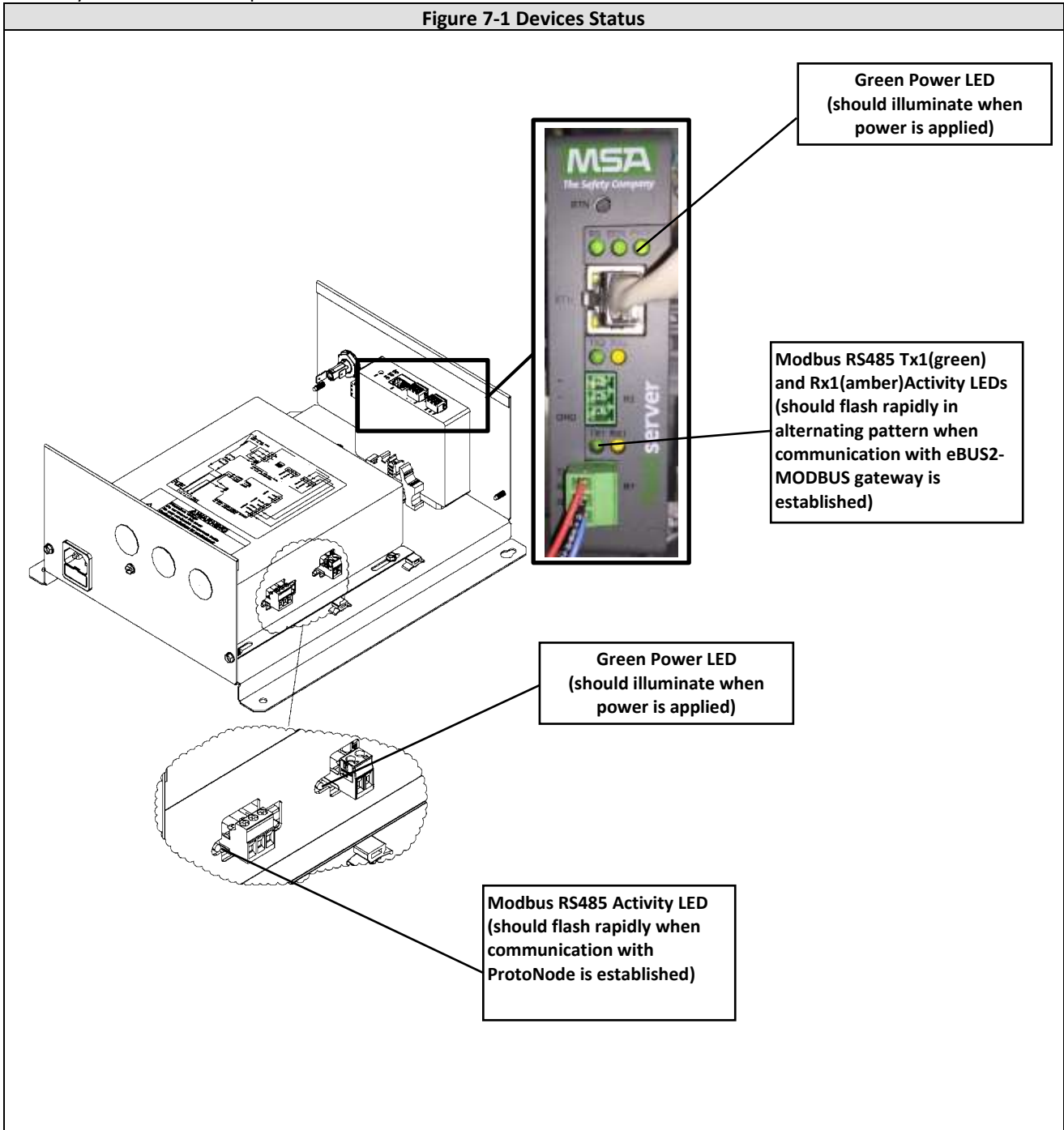

8 DATAPOINTS

BACnet Object Types: AI = Analog Input AV = Analog Value BI = Binary Input BV = Binary Value MI = Multistate Input MV = Multistate Value						
Point Name	BACnet Object	Modbus Register	Access R/W	Format	Units	Value or Range
8.1 ERRORS						
Profile ID	MI 1	0x0001	R	Unsigned 16-bit		
System Error Presence	BI 2	0x1000	R	Unsigned 16-bit		Active/Inactive (0 = Inactive, 1=Active)
Error Owner Category	MI 3	0x1001	R	Unsigned 16-bit		See Table 8-1
Error Owner Zone	AI 4	0x1002	R	Unsigned 16-bit		
Error Owner Occurrence	AI 5	0x1003	R	Unsigned 16-bit		
8.2 BUILDING MANAGEMENT SYSTEM (BMS) SERVICE						
BMS Input Power-Set	AV 6	0x2000	R/W	Unsigned 8-bit		0-255 (0=0%, 255=100%)
BMS Input Setpoint	AV 7	0x2001	R/W	Unsigned 16-bit	°C	30 - 85
8.3 CENTRAL HEATING (CH)						
Global Outdoor Sensor	AI 8	0x2002	R	Unsigned 16-bit	°C	
CH Target	AI9	0x2003	R	Unsigned 16-bit	°C	
CH Enable	BV10	0x2004	R/W	Unsigned 16-bit		Active/Inactive (0 = Inactive, 1=Active)
COOLING Enable	BV11	0x2005	R/W	Unsigned 16-bit		Active/Inactive (0 = Inactive, 1=Active)
HR Mode	BV12	0x2006	R	Unsigned 16-bit		Active/Inactive (0 = Inactive, 1=Active)
8.4 DOMESTIC HOT WATER (DHW)						
DHW Enable	BV13	0x2007	R/W	Unsigned 16-bit		Active/Inactive (0 = Inactive, 1=Active)
DHW Operation Mode	MV14	0x2008	R/W	Unsigned 16-bit		0-2 0 = DISABLED 1 = TIME BASED 2 = ALWAYS ACTIVE
DHW Comfort Temp	AV15	0x2009	R/W	Unsigned 16-bit	°C	10 - 65
DHW Reduced Temp	AV16	0x200A	R/W	Unsigned 16-bit	°C	10 - 65
DHW Target	AI17	0x200B	R	Unsigned 16-bit	°C	
8.5 CASCADE MANAGER						
Cascade Manager Status	MI18	0x2020	R	Unsigned 16-bit		See Table 8-2
System DHW Tank Temperature	AI19	0x2021	R	Unsigned 16-bit	°C	
Cascade Common flow sensor	AI20	0x2022	R	Unsigned 16-bit	°C	

8.6 COMMERCIAL BOILER MASTER						
Boiler Flow T	AI21	0x2050	R	Unsigned 16-bit	°C	
Boiler Flow T BHE1	AI22	0x2051	R	Unsigned 16-bit	°C	
Boiler Return T	AI23	0x2052	R	Unsigned 16-bit	°C	
Boiler Return T BHE1	AI24	0x2053	R	Unsigned 16-bit	°C	
DHW Tank Temperature	AI25	0x2054	R	Unsigned 16-bit	°C	
Boiler Common Flow Sensor	AI26	0x2055	R	Unsigned 16-bit	°C	
Boiler Status	MI27	0x2056	R	Unsigned 16-bit		See Table 8-2
Boiler Flame ON Counter	AI28	0x2057-0x2058	R	Unsigned 32-bit		
Boiler Flame ON Counter BHE1	AI29	0x2059-0x205A	R	Unsigned 32-bit		
Burner ON CH	AI30	0x205B	R	Unsigned 16-bit	HOURS	
Burner ON BHE1	AI31	0x205C	R	Unsigned 16-bit	HOURS	
Burner ON DHW	AI32	0x205D	R	Unsigned 16-bit	HOURS	
Burner ON BHE0	AI33	0x205E	R	Unsigned 16-bit	HOURS	
Boiler kW Size BHE0	AI34	0x205F	R	Unsigned 16-bit	kW	
Boiler kW Size BHE1	AI35	0x2060	R	Unsigned 16-bit	kW	
Boiler Gas Power BHE0	AI36	0x2061	R	Unsigned 16-bit	kW	
Boiler Gas Power BHE1	AI37	0x2062	R	Unsigned 16-bit	kW	
8.7 HEATING ZONE 1						
Operation Mode Zone 1	MV38	0x2100	R/W	Unsigned 16-bit		0-3 0 = FROST PROTECTION 1 = REDUCED 2 = COMFORT/MANUAL 3 = PROGRAMMED
Zone 1 Tday	AV39	0x2101	R/W	Unsigned 16-bit	°C	10-30
Zone 1 Tnight	AV40	0x2102	R/W	Unsigned 16-bit	°C	10-30
Tr_set_Zone_1	AI41	0x2103	R	Unsigned 16-bit	°C	
State Zone 1	MI42	0x2104	R	Unsigned 16-bit		0 -2 0 = OFF HEATING 1 = REDUCED HEATING 2 = COMFORT HEATING
Tset Zone 1	AI43	0x2105	R	Unsigned 16-bit	°C	
Zone 1 Slope	AV44	0x2106	R/W	Unsigned 16-bit	x100	20-350 (value written is divided by 100 to obtain actual value e.g. writing 250 will set slope to 2.5)
Flow Temp Heating Circuit 1	AI45	0x2107	R	Unsigned 16-bit	°C	
Room Temperature 1	AI46	0x2108	R	Unsigned 16-bit	°C	
Zone 1 Fixed Setpoint	AV47	0x2109	R/W	Unsigned 16-bit	°C	20-90
8.8 HEATING ZONE 2						
Operation Mode Zone 2	MV48	0x2200	R/W	Unsigned 16-bit		0-3 0 = FROST PROTECTION 1 = REDUCED 2 = COMFORT/MANUAL 3 = PROGRAMMED

Zone 2 Tday	AV49	0x2201	R/W	Unsigned 16-bit	°C	10-30
Zone 2 Tnight	AV50	0x2202	R/W	Unsigned 16-bit	°C	10-30
Tr_set_Zone_2	AI51	0x2203	R	Unsigned 16-bit	°C	
State Zone 2	MI52	0x2204	R	Unsigned 16-bit		0 -2 0 = OFF HEATING 1 = REDUCED HEATING 2 = COMFORT HEATING
Tset Zone 2	AI53	0x2205	R	Unsigned 16-bit	°C	
Zone 2 Slope	AV54	0x2206	R/W	Unsigned 16-bit	x100	20-350 (value written is divided by 100 to obtain actual value e.g. writing 250 will set slope to 2.5)
Flow Temp Heating Circuit 2	AI55	0x2207	R	Unsigned 16-bit	°C	
Room Temperature 2	AI56	0x2208	R	Unsigned 16-bit	°C	
Zone 2 Fixed Setpoint	AV57	0x2209	R/W	Unsigned 16-bit	°C	20-90

8.9 HEATING ZONE 3

Operation Mode Zone 3	MV58	0x2300	R/W	Unsigned 16-bit		0-3 0 = FROST PROTECTION 1 = REDUCED 2 = COMFORT/MANUAL 3 = PROGRAMMED
Zone 3 Tday	AV59	0x2301	R/W	Unsigned 16-bit	°C	10-30
Zone 3 Tnight	AV60	0x2302	R/W	Unsigned 16-bit	°C	10-30
Tr_set_Zone_3	AI61	0x2303	R	Unsigned 16-bit	°C	
State Zone 3	MI62	0x2304	R	Unsigned 16-bit		0 -2 0 = OFF HEATING 1 = REDUCED HEATING 2 = COMFORT HEATING
Tset Zone 3	AI63	0x2305	R	Unsigned 16-bit	°C	
Zone 3 Slope	AV64	0x2306	R/W	Unsigned 16-bit	x100	20-350 (value written is divided by 100 to obtain actual value e.g. writing 250 will set slope to 2.5)
Flow Temp Heating Circuit 3	AI65	0x2307	R	Unsigned 16-bit	°C	
Room Temperature 3	AI66	0x2308	R	Unsigned 16-bit	°C	
Zone 3 Fixed Setpoint	AV67	0x2309	R/W	Unsigned 16-bit	°C	20-90

8.10 HEATING ZONE 4

Operation Mode Zone 4	MV68	0x2400	R/W	Unsigned 16-bit		0-3 0 = FROST PROTECTION 1 = REDUCED 2 = COMFORT/MANUAL 3 = PROGRAMMED
Zone 4 Tday	AV69	0x2401	R/W	Unsigned 16-bit	°C	10-30
Zone 4 Tnight	AV70	0x2402	R/W	Unsigned 16-bit	°C	10-30
Tr_set_Zone_4	AI71	0x2403	R	Unsigned 16-bit	°C	
State Zone 4	MI72	0x2404	R	Unsigned 16-bit		0 -2 0 = OFF HEATING 1 = REDUCED HEATING 2 = COMFORT HEATING
Tset Zone 4	AI73	0x2405	R	Unsigned 16-bit	°C	
Zone 4 Slope	AV74	0x2406	R/W	Unsigned 16-bit	x100	20-350 (value written is divided by 100 to obtain actual value e.g. writing 250 will set slope to 2.5)
Flow Temp Heating Circuit 4	AI75	0x2407	R	Unsigned 16-bit	°C	

Room Temperature 4	AI76	0x2308	R	Unsigned 16-bit	°C	
Zone 4 Fixed Setpoint	AV77	0x2309	R/W	Unsigned 16-bit	°C	20-90

8.11 HEATING ZONE 5

Operation Mode Zone 5	MV78	0x2500	R/W	Unsigned 16-bit		0-3 0 = FROST PROTECTION 1 = REDUCED 2 = COMFORT/MANUAL 3 = PROGRAMMED
Zone 5 Tday	AV79	0x2501	R/W	Unsigned 16-bit	°C	10-30
Zone 5 Tnight	AV80	0x2502	R/W	Unsigned 16-bit	°C	10-30
Tr_set_Zone_5	AI81	0x2503	R	Unsigned 16-bit	°C	
State Zone 5	MI82	0x2504	R	Unsigned 16-bit		0 -2 0 = OFF HEATING 1 = REDUCED HEATING 2 = COMFORT HEATING
Tset Zone 5	AI83	0x2505	R	Unsigned 16-bit	°C	
Zone 5 Slope	AV84	0x2506	R/W	Unsigned 16-bit	x100	20-350 (value written is divided by 100 to obtain actual value e.g. writing 250 will set slope to 2.5)
Flow Temp Heating Circuit 5	AI85	0x2507	R	Unsigned 16-bit	°C	
Room Temperature 5	AI86	0x2508	R	Unsigned 16-bit	°C	
Zone 5 Fixed Setpoint	AV87	0x2509	R/W	Unsigned 16-bit	°C	20-90

8.12 HEATING ZONE 6

Operation Mode Zone 6	MV88	0x2600	R/W	Unsigned 16-bit		0-3 0 = FROST PROTECTION 1 = REDUCED 2 = COMFORT/MANUAL 3 = PROGRAMMED
Zone 6 Tday	AV89	0x2601	R/W	Unsigned 16-bit	°C	10-30
Zone 6 Tnight	AV90	0x2602	R/W	Unsigned 16-bit	°C	10-30
Tr_set_Zone_6	AI91	0x2603	R	Unsigned 16-bit	°C	
State Zone 6	MI92	0x2604	R	Unsigned 16-bit		0 -2 0 = OFF HEATING 1 = REDUCED HEATING 2 = COMFORT HEATING
Tset Zone 6	AI93	0x2605	R	Unsigned 16-bit	°C	
Zone 6 Slope	AV94	0x2606	R/W	Unsigned 16-bit	x100	20-350 (value written is divided by 100 to obtain actual value e.g. writing 250 will set slope to 2.5)
Flow Temp Heating Circuit 6	AI95	0x2607	R	Unsigned 16-bit	°C	
Room Temperature 6	AI96	0x2608	R	Unsigned 16-bit	°C	
Zone 6 Fixed Setpoint	AV97	0x2609	R/W	Unsigned 16-bit	°C	20-90

8.13 SOLAR MANAGER

Solar Collector Temperature	AI98	0x3000	R	Unsigned 16-bit	°C	
Storage Temp – HIGH	AI99	0x3001	R	Unsigned 16-bit	°C	
Solar Pump	AI100	0x3002	R	Unsigned 16-bit		
Solar Pump Run Time	AI101	0x3003	R	Unsigned 16-bit	HOURS	
BUF T High	AI102	0x3004	R	Unsigned 16-bit	°C	

BUF T Low	AI103	0x3005	R	Unsigned 16-bit	°C	
BUF Buffer Status	MI104	0x3006	R	Unsigned 16-bit		0 = ABSENT 1 = DISABLED 2 = OFF 3 = LOADED 4 = LOAD REQUEST 5 = ANTIFREEZE 6 = ANTIFROST 7 = HIGH SENSOR ERROR 8 = OVERTEMPERATURE

8.14 Error Owner Multistate Values			
Table 8-1 Error Owner Multistate Values			
Category	Error Owner		Device generating the error
	Zone	Occurrence	
0			Domestic Boiler Master
2			Solar Controller Low
4			Cascade Manager
5			PacMan Energy Manager
10	14	0	Zone Manager (zone 1 2 3)
10	112	1	Zone Manager (zone 4 5 6)
11			Remote IP Gateway
12			Multi Function Clip Master
13			Fresh Water Station
14			Hybrid Energy Manager EVO
21			Heat Pump TDM
23	254	1	Domestic Boiler Slave 1
23	254	2	Domestic Boiler Slave 2
23	254	3	Domestic Boiler Slave 3
23	254	4	Domestic Boiler Slave 4
23	254	5	Domestic Boiler Slave 5
23	254	6	Domestic Boiler Slave 6
23	254	7	Domestic Boiler Slave 7
26			Heat Pump Water Heater Master
27			Heat Pump PCM
36			Gas Absorption Heat Pump
38			Commercial Boiler Master
39	254	1	Commercial Boiler Slave 1
39	254	2	Commercial Boiler Slave 2
39	254	3	Commercial Boiler Slave 3
39	254	4	Commercial Boiler Slave 4
39	254	5	Commercial Boiler Slave 5
39	254	6	Commercial Boiler Slave 6
39	254	7	Commercial Boiler Slave 7
40			Gateway VMC
41			Gateway eBus2-Modbus
42	254	1	Heat Pump Water Heater Slave 1
42	254	2	Heat Pump Water Heater Slave 2
42	254	3	Heat Pump Water Heater Slave 3
42	254	4	Heat Pump Water Heater Slave 4
42	254	5	Heat Pump Water Heater Slave 5
42	254	6	Heat Pump Water Heater Slave 6
42	254	7	Heat Pump Water Heater Slave 7

8.15 STATUS CODE**Table 8-2 Status Code**

1	STANDBY
1	STANDBY
2	CH SERVING
3	DHW SERVING
4	STORAGE LOADING
5	CH TEMP REACHED
6	DHW TEMP REACHED
7	STORAGE LOADING TEMP REACHED
20	PUMP ANTIFREEZE
21	BURN ANTIFREEZE
22	TANK FROST PROTECTION
23	ANTILEGIONELLA FUNCTION
24	COMFORT PRE-HEATING
25	DHW SERVING FROM SOLAR
26	PLANT FROST PROTECTION
27	PLANT FROST PROTECTION BURN BLOCKED
30	CHIMNEY
31	AIRPURGE
34	SPECIAL TEST
35	MANUAL MODE
50	SAFETY SHUTDOWN
51	LOCKOUT VOLATILE
52	LOCKOUT NOT VOLATILE
53	BURNING BLOCKED
100	OFF
101	INIT



Visit us online



NTI Boilers Inc. 30 Stonegate Dr. Saint John, NB E2H 0A4 Canada
Technical Assistance: 1-800-688-2575
Website: www.ntiboilers.com
Fax: 1-506-432-1135