

Vmax LWCO KIT (P/N 85253)

INSTALLATION INSTRUCTIONS



Version Date: 2016-11-08

APPLICABLE BOILER MODELS:

- VM110
- VM110P
- VM153
- VM153P

NY Thermal Inc.
 30 Stonegate Dr.
 Saint John, NB
 E2H 0A4 Canada
 Technical Assistance:
 1-800-688-2575
 Fax: 1-506-432-1135
 www.ntiboilers.com



This boiler must be serviced by a qualified heating technician. Failure to properly maintain or service this appliance may result in property damage, serious injury to occupants or death.



The installation of this kit must be performed by a qualified boiler technician. Installing this kit without the proper background and training is hazardous and may result in property damage or death.

Introduction

The NTI Low Water Cutoff (LWCO) kit is intended for use with the NTI Vmax boiler models listed above; it is **NOT** intended for use with other boiler models. It is the installer's responsibility to ensure the LWCO is installed and assembled in accordance with these instructions, the Installation and Operation Instruction included with the boiler, and the Installation and Operation Instruction included with the LWCO. Check NTI LWCO kit contents to ensure all components are included, prior to commencing assembly. Contact NTI if assistance is required.

Kit Contents

Description	P/N	Qty
1. LWCO	84424	1
2. Tee, Brass, 1x1x3/4"	82759	1
3. Tee, Brass, 1x1/2x1"	84466	1
4. 40VA Transformer with Bracket	83190	1
5. Bushing, Brass, 1x3/4"	82869	2
6. Nipple, Brass, 1" x Close	82758	1
7. 1" Grommet	85254	1
8. #8-3/4" Drill Point Screw	81428	2
9. Wire Harness ¹	-	1

NOTE: ¹ Wire Harness Not Shown

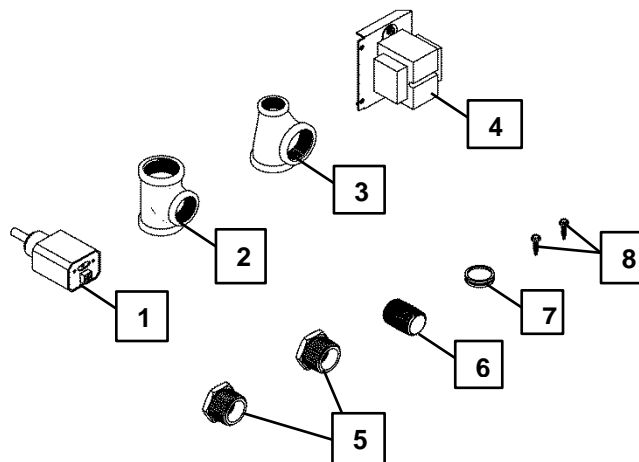

Instructions

1. **Turn Power Supply Off** and drain water from boiler.
2. **Install LWCO** as illustrated in **Figure 1** (a & b) for model VM110, and **Figure 2** (a & b) for model VM110P, VM153 and VM153P

NOTICE

Apply Teflon® tape to the treads of LWCO; hand tighten firmly, being careful not to cross the threads.

Figure 1 (a) LWCO Plumbing Assembly View VM110

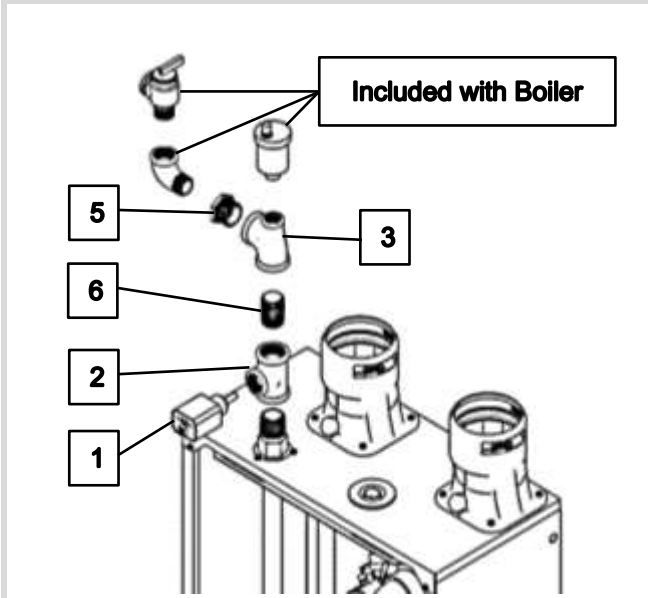

Figure 1 (b) LWCO Plumbing Assembled View VM110

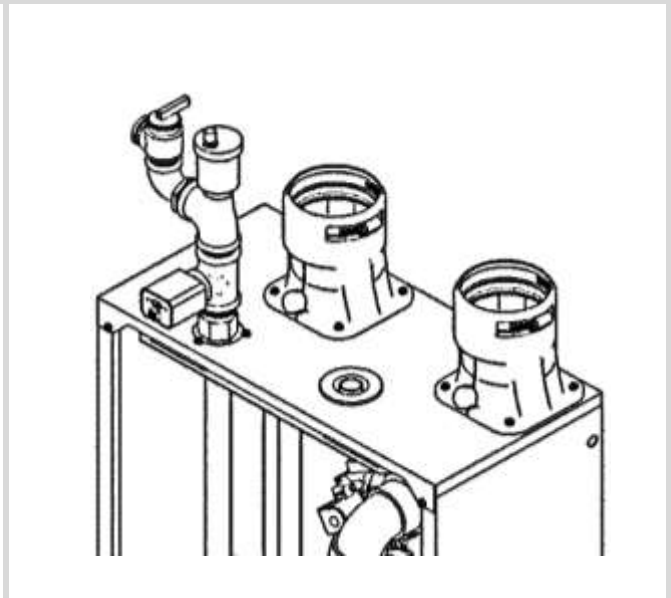

Figure 2 (a) LWCO Plumbing Assembly View VM110P, VM153 and VM153P

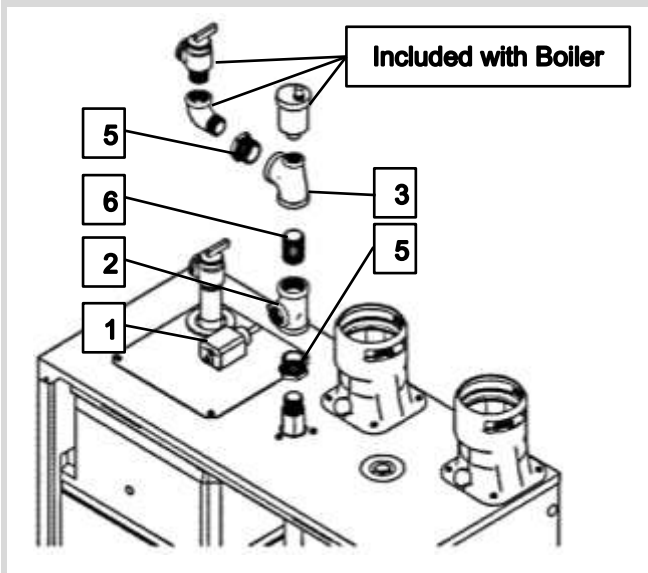
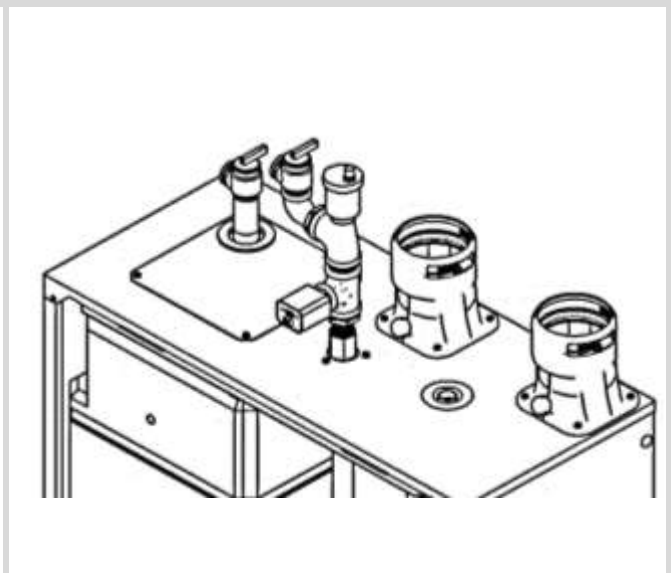

Figure 2 (b) LWCO Plumbing Assembled View VM110P, VM153 and VM153P



3. **Mount Transformer 7-1/2 in.** from the top; left side for VM110 and VM153 see **Figure 3 (a)**; right side for VM110P and VM153P see **Figure 3 (b)**.

Figure 3 (a) Mounting Transformer VM110 & VM153

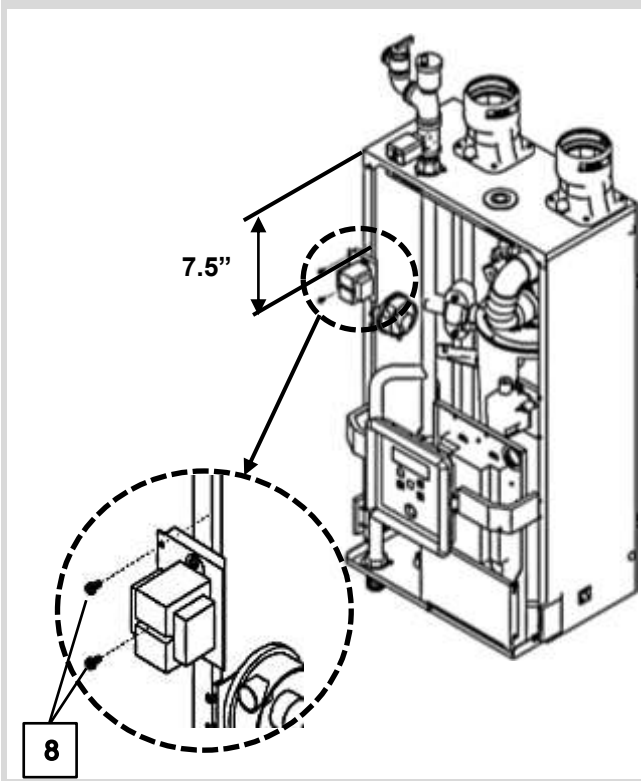
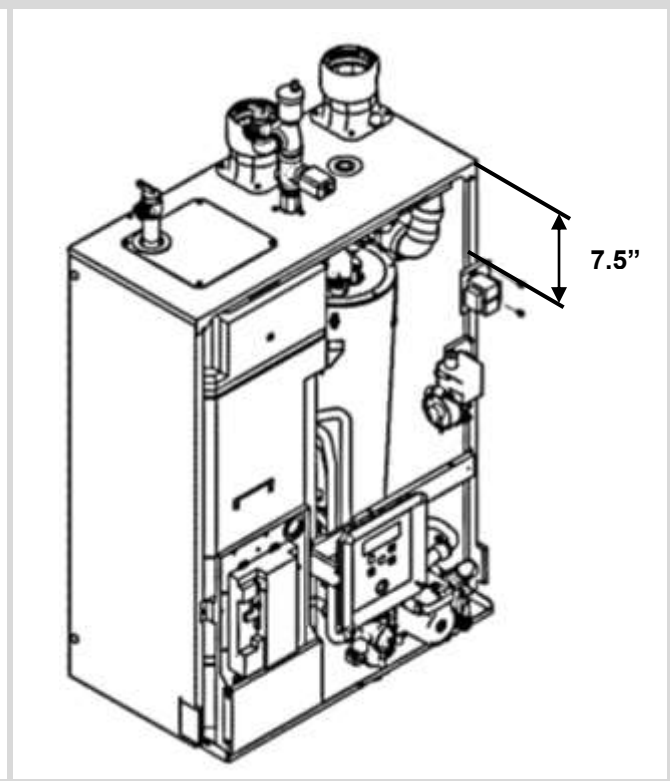

Figure 3 (b) Mounting Transformer VM110P & VM153P



4. **Drill a 1 in. hole** in the top of the boiler cabinet, for routing the LWCO wiring harness. Drill hole approximately 3 in. to the left of the water connection for model VM110 and VM153 see **Figure 4 (a)**; drill hole approximately 3 in. for the right of the water connection for model VM110P and VM153P see **Figure 4 (b)**.

Figure 4 (a) 1 in. Hole Location VM110 & VM153

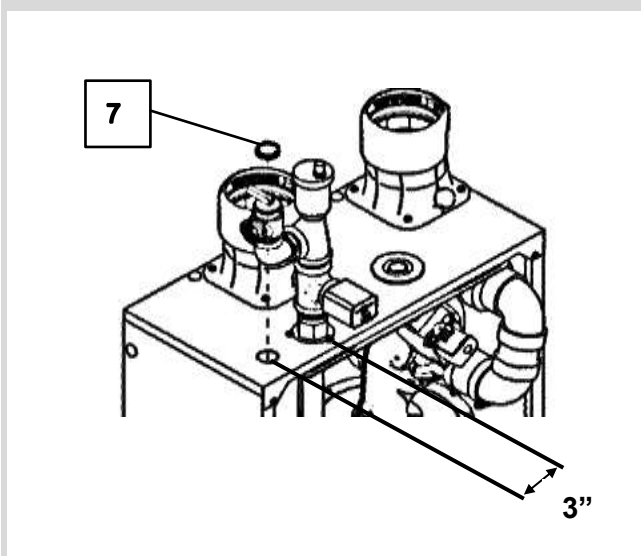
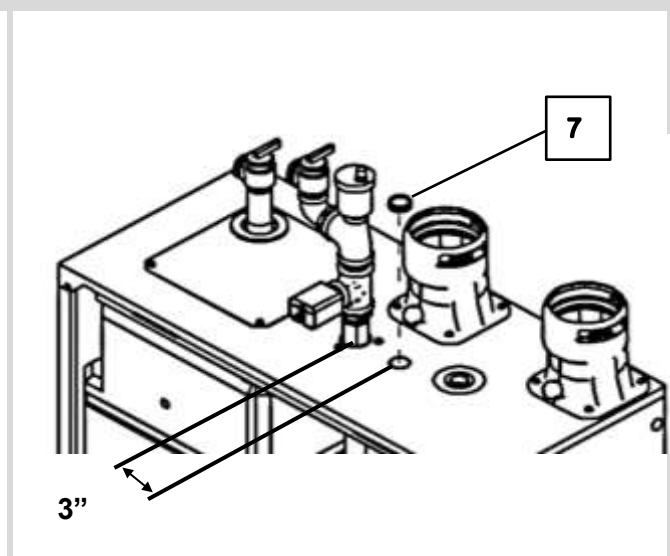
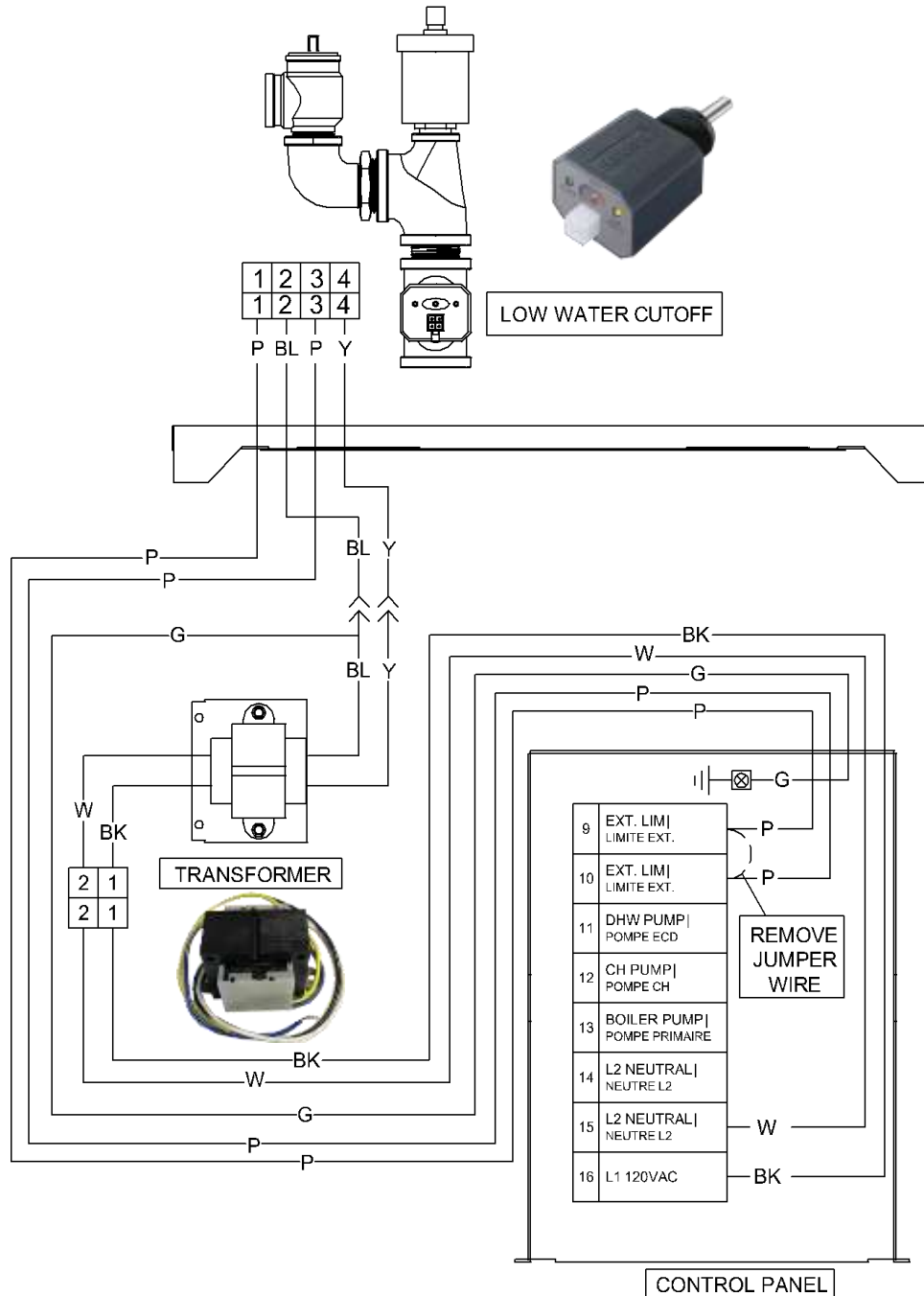

Figure 4 (b) 1 in. Hole Location VM110P & VM153P



5. **Install wire harness** as per **Figure 5**. Ensure the grommet is installed in the hole (1 in. hole in previous step) to protect the cable from being damaged.
6. **Route LWCO wire harness:**
 - a. Route LWCO wire harness in conjunction with the Vmax wire harness. Ensure to pass through the grommet of the Vmax Control Panel to prevent wire damage.
 - b. Secure Edge Clip (located on the LWCO harness) to the boiler side, just above the transformer bracket.
 - c. Ensure LWCO wire harness is located within the cabinet and will not be pinched or damaged when placing the front cover back on the boiler. Use the provided zip ties for securing the LWCO harness where needed.

Figure 5 Installing Wire Harness (VM110 Illustrated)



WARNING Failure to Remove Jumper Wire will prevent the LWCO from operating as intended in an event of low water, which may result in property damage, personal injury or death.

**CAUTION**

Do not operate boiler unattended until the following steps are completed. Failure to follow these steps may result in property damage or personal injury.

7. **Prior to filling the water level** above the LWCO, turn on power to the boiler and set thermostat to call for heat. Both the green “POWER” LED and amber “LOW WATER” should light up. The burner should **NOT** fire.

**WARNING**

If the burner fires with no water at the probe, immediately shut down the power to the boiler. Check to ensure the wire harness is not damage – Contact NTL.

8. **Pressurize the boiler**, check for leak, and ensure air vent (located above LWCO) is open. Verify the amber “LOW WATER” LED goes out.
9. **Reset the boiler; allow the burner to fire**, then push the LWCO test button to simulate a low water condition. The amber “LOW WATER” LED should light up and the burn should shut down.
10. **The Annual Maintenance and Inspection** of the LWCO is to be conducted during the annual boiler inspection. Press the TEST button to simulate a low water condition. The amber “LOW WATER” LED should light up and the burner should shut down. Remove the LWCO every five years and clean all surfaces in contact with water.

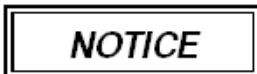
**NOTICE**

If the amber “LOW WATER” LED is flashing, the controller should be removed and all surfaces in contact with water are to be cleaned. If left unchecked, this could result in an unwanted low water shutdown.



Visit us
online



NY Thermal Inc. 30 Stonegate Dr. Saint John, NB E2H 0A4 Canada
Technical Assistance: 1-800-688-2575
Website: www.ntiboilers.com
Fax: 1-506-432-1135