

TFTN

NATURAL GAS TO PROPANE GAS CONVERSION INSTRUCTIONS

Applicable Models:

TFTN285, TFTN340, and TFTN399



WARNING

This conversion kit shall be installed by a qualified installer, service agency, or the gas supplier in accordance with the manufacturer's instructions and all applicable codes and requirements of the authority having jurisdiction. If the information in these instructions is not followed exactly, a fire, an explosion or production of carbon monoxide may result causing property damage, personal injury, or loss of life.

The qualified installer, service agency, or the gas supplier is responsible for the proper installation of this kit. THE INSTALLATION IS NOT PROPER AND COMPLETE UNTIL THE OPERATION OF THE CONVERTED APPLIANCE IS CHECKED AS SPECIFIED IN THE MANUFACTURER'S INSTRUCTIONS SUPPLIED WITH THE KIT, WHICH NECESSITATES THE USE OF A CALIBRATED CO₂/O₂ AND CO COMBUSTION ANALYZER.



Part 0. General Safety Information

NTI boilers are factory set to operate with Natural Gas. **BEFORE OPERATING WITH PROPANE** the boiler must be converted to Propane using this kit. Use the procedures outlined in these instructions to fully complete the Natural Gas to LP conversion for models **TFTN285, 340, and 399**.

Note: NTI recommends installing the LP Conversion Kit before installing the boiler or connecting the gas line.

Kit Contents:

- Natural to LP Conversion Instructions nr. 1
- LP Conversion Label nr. 1
- LP-Orifice (Table 1) nr. 1

If the kit contents do not match those specified for your boiler model (see Table 1), **DO NOT** proceed with installing the LP-Conversion Kit, and **DO NOT** operate the boiler - contact **NTI** for assistance.

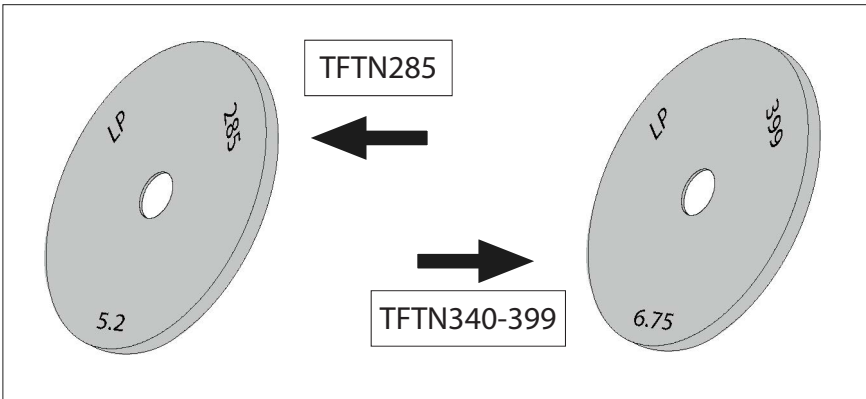

Model	LP orifice markings	LP orifice Ø	Kit Part No.
TFTN285	LP / 285 / 5.2	5.2 mm	64980652
TFTN340 TFTN399	LP / 399 / 6.75	6.75 mm	64980653

Table 1 – LP orifice

Part 0. General Safety Information



WARNING

These instructions **CANNOT** be used to convert NTI appliance models not referenced in these instructions. Contact NTI for the Natural Gas to LP conversion kit and instructions for other models.

Failure to apply these instructions properly may result in dangerous Carbon Monoxide levels, fire or explosion leading to property damage, personal injury or death.

ATTENTION:

Liquefied Petroleum (LP) propane gas is heavier than air; therefore, it is imperative that your boiler is not installed in a pit or similar location that will permit heavier than air gas to collect.

Local Codes may require appliances fueled with LP gas be provided with an approved means of removing unburned gases from the room. Check your local codes for this requirement.



WARNING

Breathing Hazard - Carbon Monoxide Gas

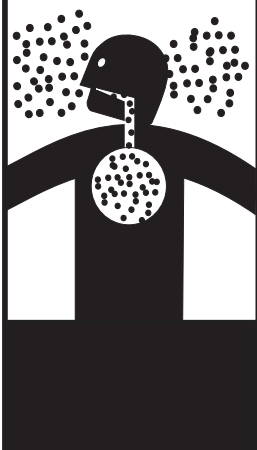

- Do not operate heater if flood damaged.
- Install vent system in accordance with local codes and manufacturers installation instructions.
- Do not obstruct heater air intake or exhaust. Support all vent piping per manufacturers installation instructions.
- Do not place chemical vapor emitting products near unit.
- According to NFPA 720, carbon monoxide detectors should be installed outside each sleeping area.
- Never operate the heater unless it is vented to the outdoors.
- Analyze the entire vent system to make sure that condensate will not become trapped in a section of vent pipe and therefore reduce the open cross sectional area of the vent.

**Breathing carbon monoxide can cause brain damage or death.
Always read and understand instruction manual.**

LP-304

Part 1. Propane Conversion Procedure

1. Install LP orifice

- a. Check that the markings on the LP orifice match those indicated for the model of boiler to be converted – see Table 1.
- b. Turn the 120VAC power supply OFF to the boiler.
- c. Turn the gas supply OFF.
- d. Remove the front cover and top access panel from the unit.
- e. (TFTN285 only) Remove the right side panel.
- f. Remove the electrical connector from the gas valve.
- g. Disconnect the gas line at the union fitting at the inlet to the gas valve.
- h. Disconnect the gas valve by removing the three screws securing it to the Venturi.
- i. Remove the rubber gasket located between the gas valve and Venturi and insert the LP orifice into the groove in the middle of the gasket; the orifice should fit securely.

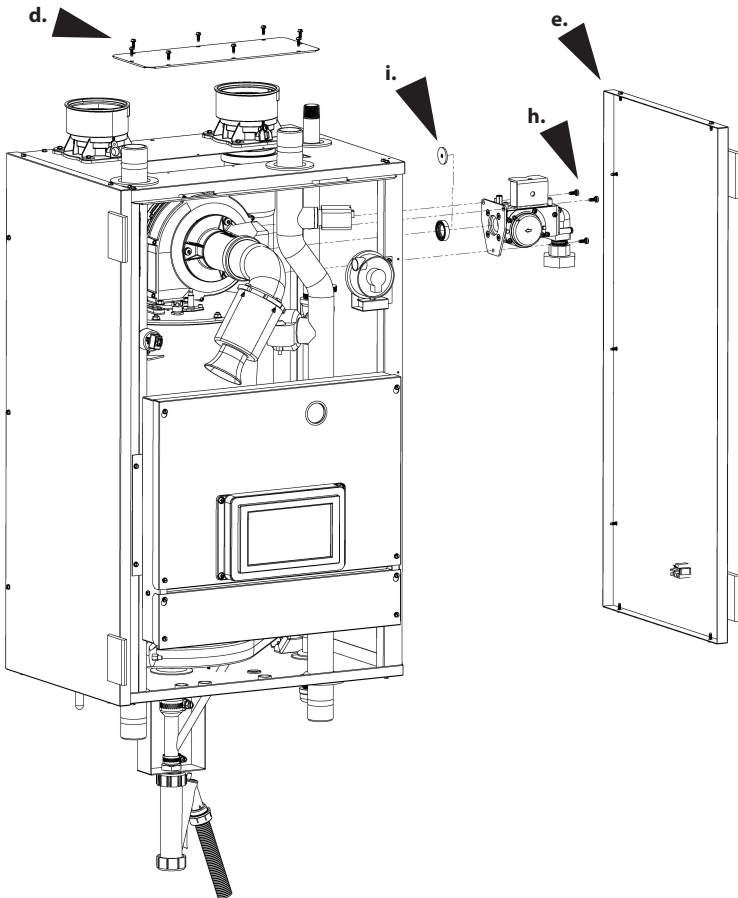

Figure 1 – Removing the gas valve from a TFTN285

Part 1. Propane Conversion Procedure

1. Install LP orifice (cont'd)

- j. Seat gasket (w/orifice) into the outlet of the Gas Valve, and re-attach the Gas Valve to the Venturi and securely tighten the three screws.
- k. Reinstall the electrical connector onto the gas valve.
- l. Reconnect the gas line at the union fitting and tighten securely while supporting both sides of the fitting.
- m. Turn gas on and check for leaks. Proceed to Section 2.0 *Gas Valve and Burner Setup*.

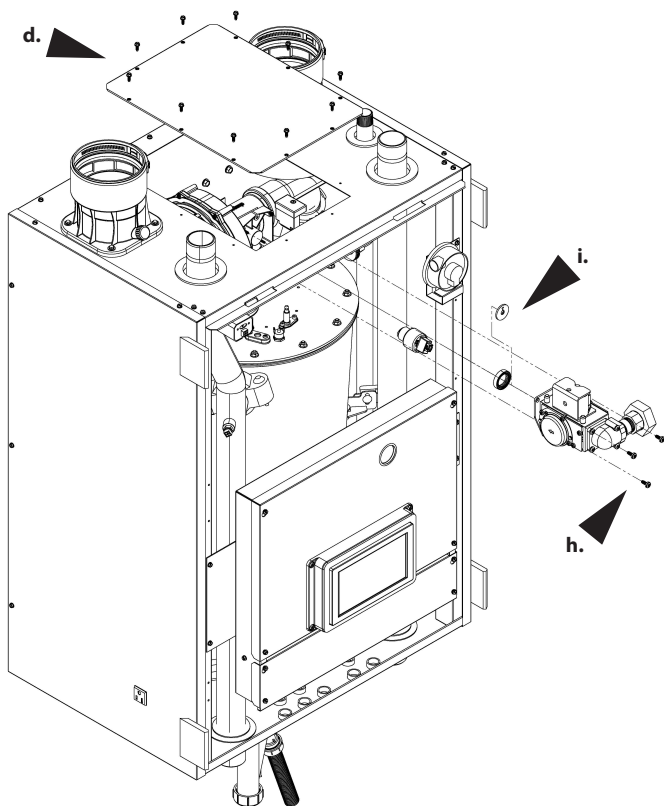

Figure 2 – Removing the gas valve from a TFTN340/399

Part 2. Gas Valve and Burner Setup



WARNING

Failure to perform the Gas Valve and Burner Setup correctly may result in incorrect operation, component failure, property damage, serious injury or death.

1. Operating Sequence

Prior to commencing the Gas Valve and Burner Setup, perform the following operating sequence check:

- Turn the supply of gas to the boiler off.
- Set the thermostat to the highest setting.
- Ensure the combustion fan pre-purges for a short time prior to activating the igniter.
- Ensure the combustion fan post-purges for at least 5 seconds prior to reactivating the igniter.
- Set the thermostat to the lowest setting and continue with the Gas Valve and Burner Setup procedure outlined below.

2. Gas Line pressure

The boiler gas valve is equipped with a Line Pressure Test Port; see screw 1, Figure 3.

Use the following procedure to measure the gas line pressure to the boiler to ensure it falls within the range given in Table 2:

- Turn the supply of gas to the boiler off.
- Loosen screw **1 (Line Pressure Test Port)**. This port is directly connected to the gas line feeding the boiler. See screw 1, Figure 3.
- Connect a gas pressure gauge to the line pressure test port using applicable tubing. Ensure both ends of the tubing make a tight connection.
- Turn the gas supply to the boiler on and check for gas leaks.
- Observe the line pressure under static conditions and compare it to Table 2. The pressure will be greatest under static conditions.

- Observe the line pressure with the boiler running, while checking/adjusting the CO₂ at Max Power and compare it to Table 2. The pressure will be lowest during the maximum flow of gas.
- Adjust the gas line pressure to ensure the parameters in Table 2 are attained under all conditions. If possible, adjust the line pressure to the "Nominal/Desired" value listed in Table 2 while the unit is operating at Max Power. Continue observing gas line pressure until completing of necessary Checking/Adjusting of the CO₂ (see Part 3), in case adjustments need to be made.
- Complete pressure testing. Remove the tubing from the test port and then return the bleed screw of the Line Pressure Test Port to the closed position. Check for gas leaks.

	Line Pressure (inches w.c.)		
	Nominal	Min.	Max.
Natural	7	3.5	10.5
Propane	11	8	13

Table 2 – Line Pressure Parameters



DANGER

Failure to close the bleed screw of the Line Pressure Test Port will cause a severe leakage of gas, resulting in a fire or explosion causing property damage, serious injury or death.

NOTICE

The line pressure is a function of the gas supply and is affected solely by field provided parameters such as line size and regulator settings. Under no circumstances can the boiler gas valve influence or be used to adjust the gas line pressure.

Part 2. Gas valve and burner setup

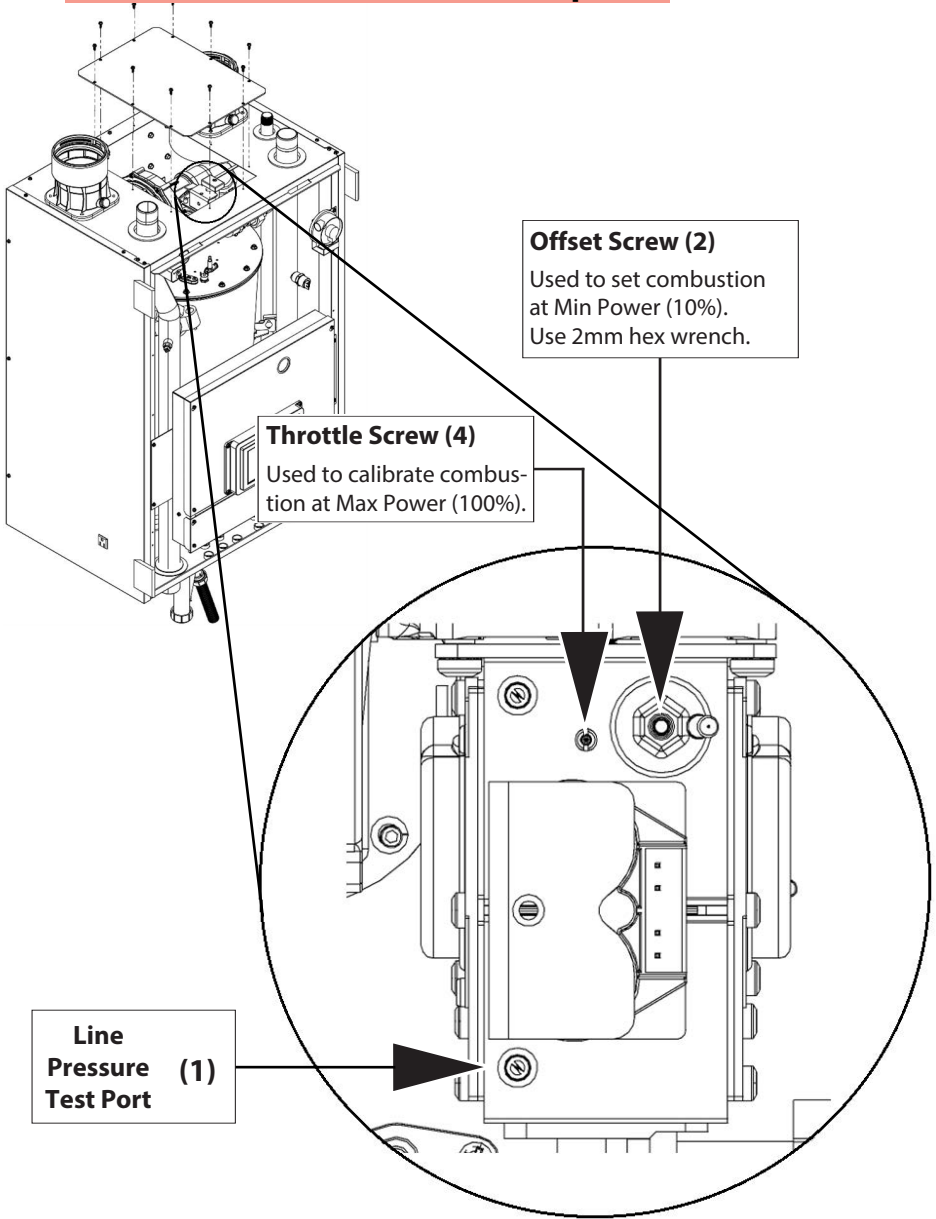

Figure 3 – Gas valve adjustment for TFTN285-399



WARNING

Adjustments to the Gas valve may only be made by a qualified gas technician, while using a calibrated combustion analyzer capable of measuring CO₂ and CO. Adjustments may only be performed if the gas line pressure is maintained above minimum levels throughout the duration of the test. See Table 3. Failure to follow these instructions may result in serious injury or death.



WARNING

FAILURE TO PERFORM THE FLUE GAS ANALYSIS AND ADJUSTMENT AS DETAILED IN THIS SECTION MAY RESULT IN ERRATIC AND UNRELIABLE BURNER OPERATION, LEADING TO REDUCED EFFICIENCY, INCREASED FUEL CONSUMPTION, REDUCED COMPONENT LIFE, HEAT EXCHANGER COMBUSTION DEPOSITS, AND GENERAL UNSAFE OPERATION. FAILURE TO FOLLOW THESE INSTRUCTIONS MAY RESULT IN SERIOUS INJURY OR DEATH.



WARNING

It is required to use a calibrated combustion analyzer to verify final adjustment according to the combustion chart (Table 3). Failure to do so could result in serious personal injury or death.

NOTICE

Make sure the analyzer is set to the appropriate fuel.

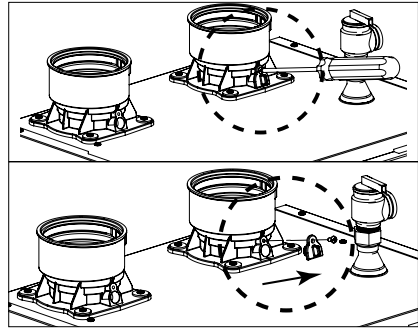

Figure 4 – TFTN285 Combustion Test Port

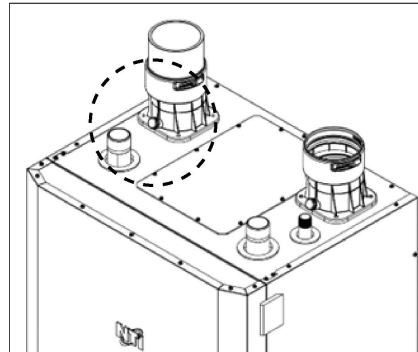

Figure 5 – TFTN340-399 Combustion Test Port

1. Preparing the measuring equipment

Remove the Combustion Test Port plug / cap, as illustrated (Figures 4 & 5), and insert a calibrated combustion analyzer.



WARNING

It is very important that the combustion system be set within the recommended CO₂ & CO measurements listed in Table 3. Visually looking at the burner does not determine combustion quality. Failure to measure combustion with a calibrated combustion analyzer and set the throttle within the recommended CO₂ & CO measurements could result in property damage, severe personal injury, or death.

Part 3. Checking/Adjusting the CO₂ at Max and Min Power

2. Checking/Adjusting the CO₂ at Max Power

Set the thermostats at the highest possible setting to create a demand for heat.

Select Max Power from the Test Mode – Burner Test screen, then wait for the Burner Power gauge to reach 100%.

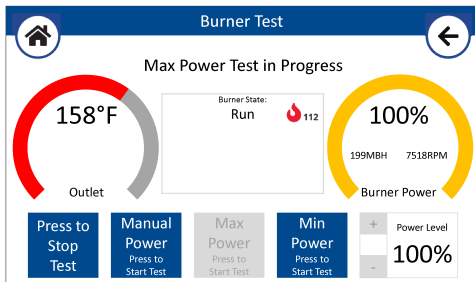

Wait 1 minute for the boiler to stabilize before carrying out the combustion analyses. Read the CO₂ value (%) and compare it with the values given in the table below:

Gas	CO ₂ (%)		CO (ppm)
	Max Power (100%)	Min Power (10%)	
NG	8.9 – 10.0	8.5 – 9.6	<175
LP	9.9 – 11.0	9.5 – 10.6	<175

Table 3 – CO₂ Max – Min

ATTENTION:

The CO₂ at Min Power must be set lower than the CO₂ at Max Power by 0.4 – 0.8% (e.g. if, using LP, the CO₂ at Max Power = 10.3%, the CO₂ at Min Power must be between 9.5 – 9.9%).

ATTENTION!! Values must be obtained with the front cover installed.

If the CO₂ reading differs from the values given in Table 3, adjust the gas valve following the instructions below. Otherwise move directly to the next operation.

Adjusting the Gas Valve at Max Power

Adjust the gas valve by turning throttle screw (4) counterclockwise to increase the CO₂ level; clockwise to reduce the CO₂ level.

Adjust in increments of 1/16th of a turn, waiting 1 minute after each adjustment.

NOTE: when switching direction between clockwise and counterclockwise, it may take a half to a full turn before a change in CO₂ is realized.

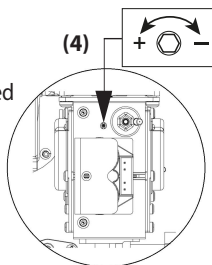

Figure 6 – Max Power CO₂ Adjustment

When the measured value corresponds to the value given in Table 3, Max Power adjustment is complete.

ATTENTION!!

Test Function will automatically deactivate after 30 minutes. Test Function can be turned off manually by pressing the RESET button.

3. Checking/Adjusting the CO₂ at Min Power

Select Min Power from the Test Mode – Burner Test screen, then wait for the Burner Power gauge to reach 10%.

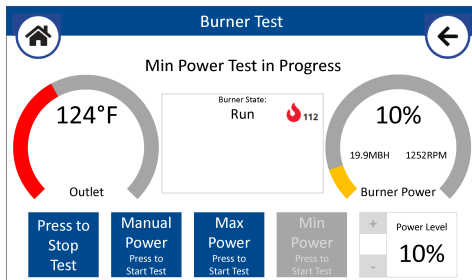

Wait 1 minute for the boiler to stabilize before carrying out the combustion analyses.

Part 3. Checking/Adjusting the CO₂ at Max and Min Power

If the CO₂ (%) reading at Min Power is not 0.4 – 0.8% lower than the CO₂ (%) reading at Max Power, adjust the gas valve following the instructions below. Otherwise move directly to the next operation.

Adjusting the Gas Valve at Min Power

Remove cap and adjust screw **2** by turning counter-clockwise to reduce the CO₂ level;

clockwise to increase it.



Wait 1 minute after each adjustment for the CO₂ value to stabilize.

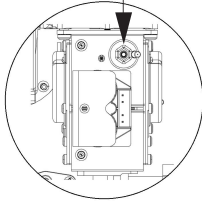

Figure 7 - Min Power CO₂ Adjustment

WARNING! Min Power adjustment is very sensitive.

If the value measured corresponds to the value given in Table 3, Min Power adjustment is complete. Otherwise continue with the procedure.

4. Ending Adjustment

1. Exit Test Mode by pressing the '**Press to Stop Test**' button (located in the lower-left corner of the Burner Test screen).
2. Turn down the thermostats and / or stop the DHW draw.
3. Reinstall the Combustion Test Port plug (see Figures 4 & 5).
4. Check for and repair any gas leaks.
5. Reinstall the front cover.

! WARNING

Carbon Monoxide - Never leave the unit operating while producing Carbon Monoxide (CO) concentrations in excess of the values indicated in Table 3. Failure to follow this warning may result in serious injury or death.

! WARNING

Breathing Hazard - Carbon Monoxide Gas



- Do not operate heater if flood damaged.
- Install vent system in accordance with local codes and manufacturers installation instructions.
- Do not obstruct heater air intake or exhaust. Support all vent piping per manufacturers installation instructions.
- Do not place chemical vapor emitting products near unit.
- According to NFPA 720, carbon monoxide detectors should be installed outside each sleeping area.
- Never operate the heater unless it is vented to the outdoors.
- Analyze the entire vent system to make sure that condensate will not become trapped in a section of vent pipe and therefore reduce the open cross sectional area of the vent.

Breathing carbon monoxide can cause brain damage or death. Always read and understand instruction manual.

LP-304

Model	Min Power		Max Power	
	Burner Power	MBH	Burner Power	MBH
TFTN285	10%	28.5	100%	285
TFTN340		39.9		340
TFTN399				399

1. Canada: Altitudes between 2000-4500 ft, de-rate by 10%. Consult local authorities for de-rating for altitudes above 4500ft.
 2. USA: De-rate capacity by 4% for every 1000 ft above sea level, if altitude is above 2000 ft.

Table 4 - Gas Input at Min and Max Power

Part 3. Checking/Adjusting the CO₂ at Max and Min Power

5. Update rating plate

As the certified installer of the Natural Gas to LP Conversion Kit, you must indicate on the boiler that it has been converted for use with Propane (LP) Gas:

- a. Update Rating Plate Decal** – Locate the rating plate decal on the side of the appliance. Using a regular ink pen, check the box next to “Field converted to Propane Gas” and fill in the date. Press hard enough to permanently mark the decal. See Figure 9.

FACTORY SET FOR NATURAL GAS Field converted to Propane Gas <input checked="" type="checkbox"/> Date: <u>October 22, 2018</u>	ADJUSTER A L'USINE POUR GAZ NATURAL Convertie au propane sur place <input type="checkbox"/> Date: _____	
Gas Pressure [Pression du Gaz]	Natural [Naturel]	Propane
Maximum Inlet Gas Pressure [Pression maximale d'entrée du gaz]	10.5" wc [2.6 kPa]	13" wc [3.2 kPa]
Minimum Inlet Gas Pressure [Pression minimum d'entrée du gaz]	3.5" wc [1 kPa]	8" wc [2 kPa]
Manifold Pressure [Pression d'admission]	0" wc [0 kPa]	0" wc [0 kPa]

Figure 9 - Update the Rating Plate Decal

b. Conversion Decal

Fill out the required information on the Conversion Decal (included in this kit) and affix it to the boiler cabinet adjacent to the rating plate decal, in a location where it can be easily seen. See Figure 10.

<p>This appliance was converted on <u>13 / 02 / 2024</u> (Day / Month / Year)</p> <p>to <u>Propane</u> gas, with Kit No. <u>99984386-1</u></p> <p>by <u>Company Name, Street #, City, State/Province, Zip/Postal Code</u></p> <p>_____ (name and address of organization making this conversion)</p> <p>that accepts responsibility for the correctness of the conversion.</p> <p>Reference rating plate for gas input and pressures.</p>
--

Figure 10 - Conversion Decal



Visit us online

NTI Boilers Inc.
30 Stonegate Drive Saint John,
NB E2H 0A4 Canada
Technical Assistance: 1-800-688-2575
Website: www.ntiboilers.com
Fax: 1-506-432-1135

87750 Rev. 24.02.16

